

Copyright 2005  
Release B  
06/23/2011

# **GOLD PROBE**

INSTRUCTION MANUAL  
M4501

**SSi** SUPER SYSTEMS INC.

7205 Edington Drive • Cincinnati, Ohio 45249 1-513-772-0060 • 1-800-666-4330 •  
FAX 1-513-772-9466

# **Table Of Contents**

- ◆ Introduction ..... 1
  
- ◆ Specifications ..... 1
  
- ◆ Characteristics ..... 2
  
- ◆ Operating Theory ..... 3
  
- ◆ Installation ..... 4
  
- ◆ Maintenance ..... 5
  
- ◆ Troubleshooting ..... 7
  
- ◆ Control Systems ..... 8
  
- ◆ Warranty ..... 10

## **INTRODUCTION**

Thank you for selecting the **Gold Probe™** for your atmosphere control application.

The Gold Probe™ represents “state of the art” in carbon sensor technology. It has been designed for use in carbon control systems as applied to both carbon control in atmosphere furnaces and dew point in endothermic generators.

The Gold Probe™, with its unique measuring electrode construction, is the product of a team of design and application engineers, each with over twenty years of atmosphere control experience. The SSi engineering team has long recognized that the sensor is the most critical component in the atmosphere control system and has traditionally been the weakest link. Now, reliability, repeatability and accuracy are assured with the inclusion of the Gold Probe™ in *your* control system.

## **SPECIFICATIONS**

- ◆ Useful %C Range- .01 to 1.6%
- ◆ Temperature Range- 1200°F to 2000°F (649°C to 1093°C)
- ◆ Stability- within +/- 1 mVDC
- ◆ Impedance- less than 10 kohms @ 1700°F (927°C)
- ◆ Useful output- 0 to 1250 mVDC
- ◆ Length- 21 1/2", 25 3/4", 35" (546mm, 654mm, 889mm)
- ◆ Weight- 3.7, 4.0, 5.8 lbs
- ◆ Insertion- 14.3", 18.6", 20" or 27.8" (363mm, 472mm, 508mm, or 706mm)
- ◆ Mounting- 1" (25.4mm) NPT
- ◆ Sheath dia.- 0.84" (1/2" pipe) (21mm, 13mm pipe)

**CHARACTERISTICS**

The typical zirconia carbon sensor consists of a closed end tube with the sensing portion at the tip. The entire tube may be zirconia or there may be a slug of zirconia cemented in the tip. Fig.1 illustrates the Gold Probe™ design with details omitted for clarity. The tip of the tube is spring loaded into contact with the sheath, which also serves as the outer electrode. The inner electrode is spring loaded into contact with the inner zirconia surface. A thermocouple is positioned close to the inner electrode surface and reference air bathes the sensing surface.

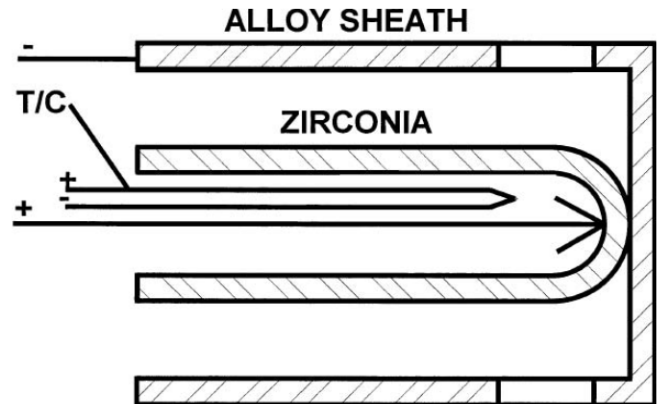

**FIG. 1**

To the instrument technician, the probe looks like a battery (see Fig.2.) It displays a voltage,  $E_c$ , from which the carbon potential can be calculated. The probe thermocouple is shown next to the sensing electrode.

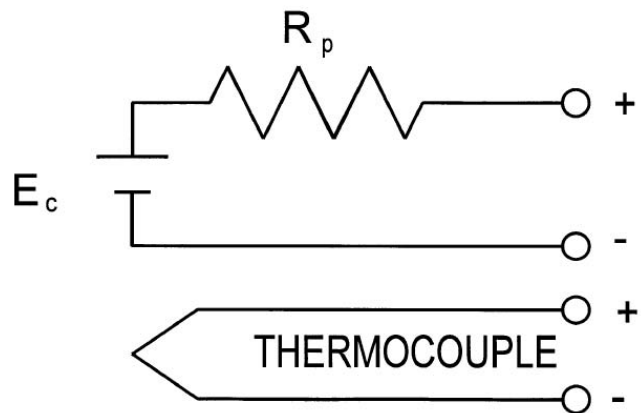

**FIG. 2**

The value of the internal resistance can be measured, as shown in Fig. 3, by putting a shunt resistor across the probe, measuring the resultant voltage,  $E_m$  and carrying out the simple calculation shown.

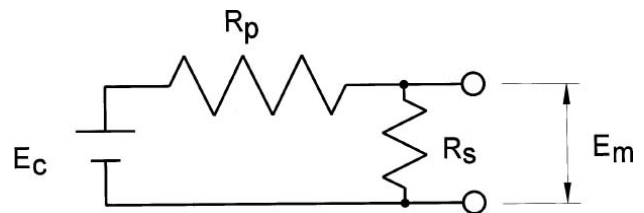

$$R_p = ((E_c/E_m) - 1) \times R_s$$

**FIG. 3**

## BASIC OPERATING THEORY

**Carbon potential** of a conventional furnace atmosphere is defined as the %C achieved in a coupon of carbon steel shim stock equilibrated in the furnace atmosphere. Unfortunately, equilibration time is long, so it is impossible to continuously control the atmosphere on the basis of shim stock measurements. A zirconia sensor, however, can be used to measure and control the carbon potential precisely, and on a continuous basis.

Strictly speaking, the zirconia probe is not sensing carbon at all. It is an oxygen sensor with a mVDC output described by Equation (1).

Fortunately, an empirical (experimental) relationship exists between oxygen concentration and carbon potential, and this relationship has been used in carbon control instruments since the early '70's. The equation used by most control manufacturers today is illustrated by Equation (2), which states that there are only *three* variables affecting the measured millivoltage. Because the actual equation used is somewhat complex, it is not reproduced here. A full description of probe theory will be found in SSi technical bulletin T4401 (Zirconia Sensor Theory).

*All* competitive probes will invariably agree within one or two millivolts when exposed to the same atmosphere under equilibrium conditions. Differences in values listed by probe vendors relate to differences in manufacturers' source data, but the true value of the zirconia probe is its repeatability.

## ZIRCONIA O<sub>2</sub> RESPONSE

$$E_c = 0.0276T_R \log (P_f / P_a) \text{ millivolts} \quad (1)$$

## Zr PROBE ALGORITHM

$$\%C = \Phi (E_c, \%CO, T_R) \text{ mVDC} \quad (2)$$

Where:  $\Phi$  means 'is a function of'

%C is the carbon potential

%CO is carbon monoxide percentage

$T_R$  is the absolute temperature in degrees Rankine (deg. F + 460).

and  $E_c$  is the probe output in millivolts.

## INSTALLATION

If your new probe is to be installed in an existing probe entry, be advised that your warranty requires that the probe should extend no more than 4" (101mm) into the furnace chamber. This is because, at operating temperatures, the sheath can sag enough to cause breakage of the zirconia-sensing element.

For new installations, an *entry fitting* must be provided at the furnace wall to permit the probe to extend from 2" to 4" (51mm to 101mm) into the furnace chamber. Listed here are several conditions that should be considered when choosing a location for the entry fitting. Most of these conditions allow for some compromise, and represent, at best, recommendations.

A variety of fittings have been used to provide the 1" (25.4mm) NPT entry. The simplest is the 1 1/2" (38mm) coupling, as shown in Fig. 4.

The furnace is prepared by drilling a 1 1/2" (38mm) diameter hole through the wall and the insulation. The hole *must* be at right angles to the wall to avoid interference with probe insertion. The fitting is then welded or screwed to the wall to provide a gas-tight entry.

Your **Gold Probe™** has been shipped with an o-ring compression fitting which allows you to adjust the insertion. Manual tightening of the cap is adequate for side mounting. A wrench should be used for vertical mounting to assure probe will not move. When installing in a hot furnace, insert the first four inches directly, then at a rate of 2" (51mm) per minute in order to avoid thermal shock fracture.

### NOTE:

Your Gold Probe™ has been thoroughly tested in our controlled atmosphere furnace. Therefore, the sheath shows evidence of thermal discoloration.

### ENTRY FITTING LOCATION

- ◆ In top third of work zone.....
- ◆ Close to control thermocouple.....
- ◆ Distant from radiant tubes.....
- ◆ Away from carrier gas entry.....
- ◆ Clear of work baskets.....

### WARNING

**Zirconia is thermal shock sensitive. Insert into hot furnace no faster than 2" (51mm) per minute (after first 4 inches or 101 millimeters).**

## INSTALLATION (CONT'D)

If you already have a control system for your carbon sensor, you have been provided with a reference air supply and perhaps a probe conditioning system as well (see Fig. 6). It is important to emphasize that the reference air be *clean and dry*. Any combustibles or moisture in the reference air will cause the sensor to read low, resulting in over-carburization. Avoid the use of lubricated plant compressed air. Air connection at the sensor should be silicone rubber tubing to avoid problems related to the high temperatures normally encountered at the sensor connection block.

Your final installation should look similar to that of Fig. 4.

## MAINTENANCE

**Furnace conditioning:** The destructive effect of carbon and temperature at high levels is conceded by manufacturers who normally instruct in the art of “*gentle burnout*”. SSi engineers have developed an even gentler routine that shortens or eliminates the time required to “*season*” the furnace after a burnout has been completed. The recommended routine for burnout is to set the temperature to 1500°F (815°C), discontinue the carrier gas, and start to add air at a rate that will not cause a large increase in temperature. A flow rate of about 10% of the normal flow of carrier gas has been found adequate. Eventually, the **Gold Probe™** output will fall to 200 mV. At this point, discontinue the air and observe the probe output. If the output rises above 250 millivolts in less than 15 minutes, turn the air on and repeat the routine until the mV level remains below 250 for more than 15 minutes. Burnoff is complete. See Fig.5.

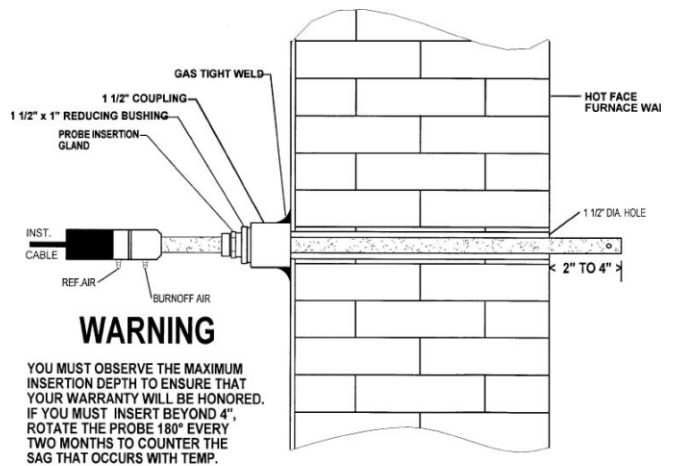

Fig. 4

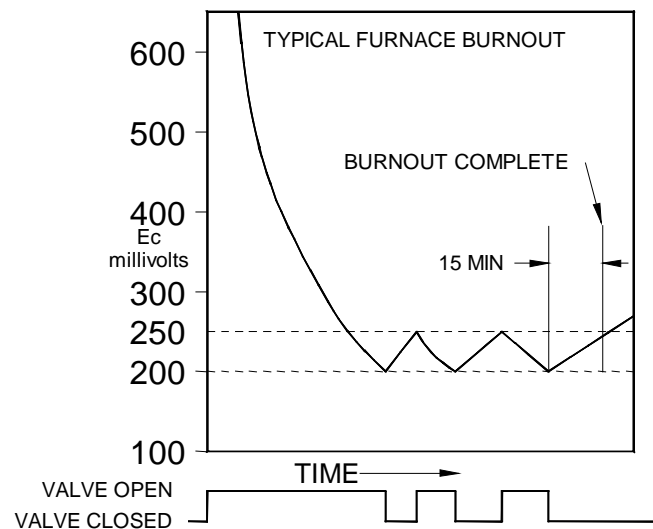

Fig. 5

Maintenance (con't)

The reason this technique is superior is that the carbon retained in the pores of the refractory is what constitutes "seasoning". Complete burnout, however gentle, removes this carbon and requires that it be added during a Monday morning start-up seasoning routine, in order to achieve operating levels.

**Probe conditioning:** While periodic furnace burnout is desirable, the process by which solid carbon or 'soot' is deposited continues in the probe, and must be remedied more frequently to keep the probe in peak operating condition. SSi technical staff has pioneered in techniques to achieve this. Soot deposition occurs in two critical locations; the annular space between the sheath and the measuring surface and at the measuring junction between the zirconia and the contact point with the sheath, which is the measuring electrode. The probe is burnt out by the flowing air into this space through the burnout fitting provided. The flow of air must be set at a rate that allows a temperature rise of no more than 100 degrees Fahrenheit (38 degrees Celsius). If possible the flow should be set high enough to overcome the effect of the work chamber fan and drop the output voltage well below 200 MV. Conducting this process for a 90 second period before or after each batch, or every six to twelve hours in a continuous furnace, will provide adequate conditioning in most cases. See Fig. 6.

TYPICAL PROBE BURNOUT SYSTEM

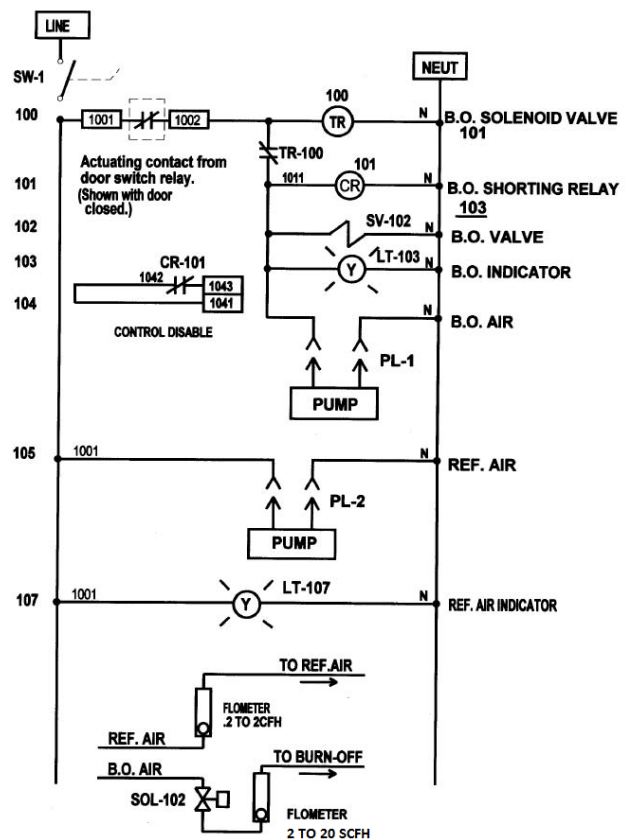

Fig. 6

## TROUBLE SHOOTING

When trouble arises with a furnace control system, it is important to establish where the problem is located; the probe, signal transmission lines, the control instrument, or the furnace itself. Several simple tests can help to isolate the problem quickly. It is most important to first understand the nature of the fault. Aside from erratic behavior like cycling, or failure to stabilize at the set point, the most common symptom is non-conformity of the work pieces to quality assurance specifications.

To evaluate most faults, the recommended tools are:

1. a good 3 ½ digit millivolt meter with at least 10 megΩ input impedance and 0 to 1999 mV range,
2. a temperature calibrator and,
3. a simulator to output 0 to 1300 millivolts at less than 50 megohms output impedance.

**Probe troubleshooting:** In order to establish the source of problems in your installation, first *resist the temptation to remove the Gold Probe from the furnace.* All of the following meaningful questions must be answered while your Gold Probe (or any other carbon sensor) is in the furnace, at temperature, and exposed to a normal atmosphere under **manual** control:

1. Does an Alnor dew point reading (or shim stock analysis) verify the indicated value from the probe? If there is reasonable correlation, the problem is NOT the probe.
2. Are the connections from the T/C extension wire and sensor cable clean and firmly attached at the correct probe and control instrument terminals? Note that the shield wire in the sensor cable should be connected to ground at the control instrument end only!

<u>SYMPTOM</u>	<u>POSSIBLE CAUSE</u>
<b>High % C</b>	<ul style="list-style-type: none"> <li>◆ <b>Low reading due to:</b> <ul style="list-style-type: none"> <li>● <b>High probe resistance</b></li> <li>● <b>Cracked zirconia</b></li> <li>● <b>Dirty reference air</b></li> <li>● <b>Faulty cable insulation</b></li> <li>● <b>Instrument calib./ calc.</b></li> <li>● <b>Air leak to burnoff fitting</b></li> <li>● <b>Furnace air leak at probe</b></li> </ul> </li> <li>◆ <b>Oily parts or sooted furnace</b></li> <li>◆ <b>Wrong recipe time/temp</b></li> </ul>
<b>Low % C</b>	<ul style="list-style-type: none"> <li>◆ <b>High Reading due to</b> <ul style="list-style-type: none"> <li>● <b>Probe plugged with soot</b></li> <li>● <b>Instrument calib./calc.</b></li> </ul> </li> <li>◆ <b>Wrong recipe time/ temp</b></li> </ul>
<b>Erratic</b>	<ul style="list-style-type: none"> <li>◆ <b>Faulty signal due to</b> <ul style="list-style-type: none"> <li>● <b>Bad sensor connections</b></li> <li>● <b>Electrical noise source</b></li> <li>● <b>Radiant tube leak</b></li> <li>● <b>Bad Endo</b></li> <li>● <b>Mixing valve setting</b></li> <li>● <b>Instrument setting</b></li> </ul> </li> </ul>
<b>Sooted fce</b>	<ul style="list-style-type: none"> <li>◆ <b>Endo not cracked (temp too Low in generator or Catalyst inactive)</b></li> </ul>

3. Is the control instrument CO or H<sub>2</sub> factor set to the appropriate value? This “factor” is referred to by various manufacturers as Zone Factor, Process Factor, Gas, Furnace Factor, CO Factor, Calibration Factor, etc. This factor may require adjustment in order to make the calculated %C or dew point agree with other measurements.
4. Do the actual Gold Probe temperature and O<sub>2</sub> mV signal, as measure by the temperature calibrator, and digital voltmeter, agree with the displayed values on the control instrument? If not, and instrument calibration problem is likely.

## GOLD PROBE MANUAL

### TROUBLESHOOTING (cont'd)

5. Is the probe impedance less than 50 kilohms at temperatures above 1550°F (843°C)? Conduct the test shown in Fig. 3 using a shunt resistor greater than 50 kilohms. Measure the voltage  $E_C$  before shunting, then  $E_M$  with the shunt in place. Calculate  $R_P$ . If it exceeds 50 kilohms, proceed to step 8, below.
6. How quickly does the probe react to a change in  $O_2$  concentration? Read the probe millivolts with the controller or the digital meter. Short the probe for 5 seconds, remove the short and measure the time required to return to within 1% of the original reading. If it exceeds 30 seconds, proceed to step 8, below.
7. Is there a leak in the zirconia substrate? To test this property, turn off the reference air for one minute. Measure the probe mV as indicated by the controller or a digital voltmeter. Turn the air back on and measure the mV again. If there is a difference greater than 25 mV, replace the probe.
8. If probe resistance or response times are questionable as indicated in steps 5 and 6, we recommend that the probe be burned off. Introduce 10 to 15 CFH of air to the burnoff fitting for about 90 to 120 seconds, and then repeat the tests. Should problems persist, it may be necessary to conduct a thorough furnace burnout so that all potentially contributing contamination is removed from all parts of the furnace, including the Gold Probe. Burning off the probe will not harm this product provided the probe temperature does not exceed 2000°F (1093°C) during the burnoff procedure.
9. Should it be necessary to remove your Gold Probe from a hot furnace, do so carefully. **UNDER NO CIRCUMSTANCES** should it be removed faster than 2" (51mm) per minute.
10. Failing resolution of your atmosphere control problems our technical support staff is available Mon. - Fri. 7:00 a.m. to 7:00 p.m. to assist and serve our heat treating customers. Call us at (800) 666-4330.

### CONTROL SYSTEMS

If you are using the Gold Probe as a replacement in an existing system, you will find that performance is as good as or better than you are accustomed to. If you plan on a new system to upgrade your controls, you can rely on Super Systems to provide you with exactly what you need. From the simplest on/off controls to the most sophisticated programmable PID controls with computer interface, data logging, production tracking, recipe design, scheduling, reports, integrated

order entry and invoicing. Fig. 7 and Fig. 8 illustrate simple control and probe conditioning systems as supplied by Super Systems. SSi is positioned to provide a "plug and play" system that is operator friendly. Components such as valves, flow meters, cable and tubing are supplied with each SSi system so that no search and purchase effort is involved in installation.

CONTROL SYSTEMS (cont'd)

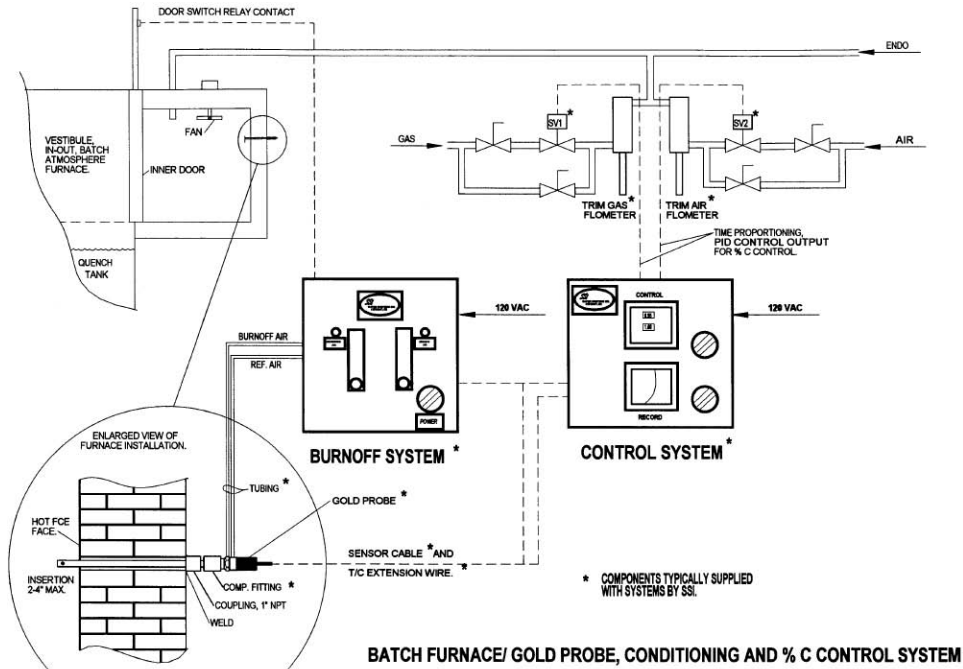

Fig. 7

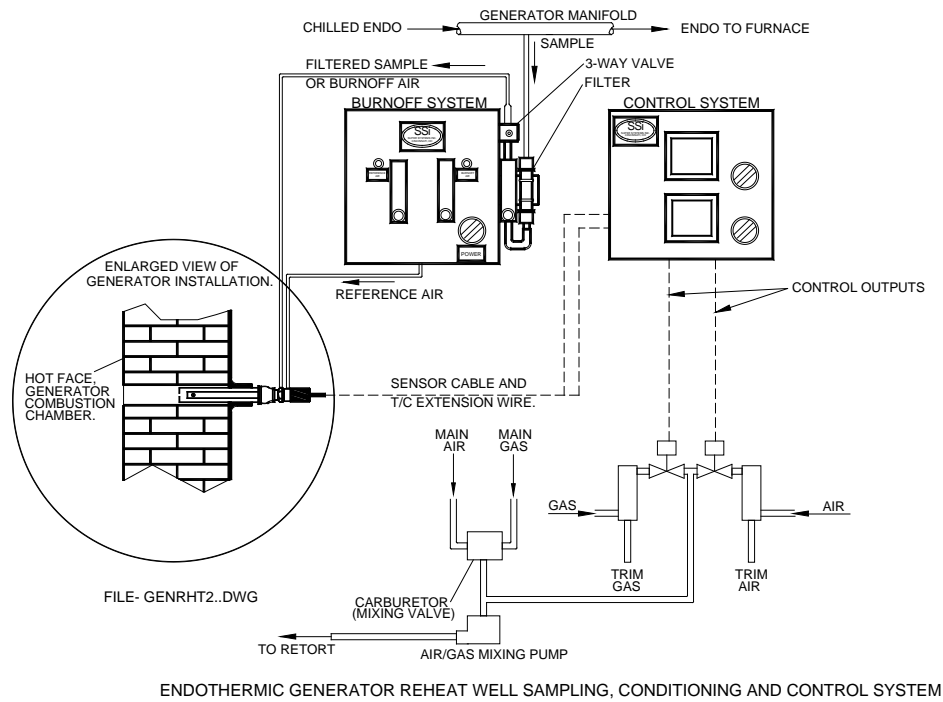

Fig. 8

## WARRANTY

- **Super Systems Inc. (SSi), as manufacturer of the Gold Probe™, warrants it to be free from defects in material and workmanship under normal use and service. SSi's obligation under this warranty is limited to repairing or replacing, at its option, the sensor described herein, should failure occur within the one-year warranty period. The warranty period shall commence on installation of the sensor, as certified by receipt of the postage free Registration Card accompanying the sensor. If premature failure occurs, the sensor, along with the Warranty Claim Report, must be returned in the complete, original packaging to SSi. Upon receipt, SSi will conduct an examination as to the cause of failure, at which time appropriate action will be taken.**
- **There are no warranties, expressed or implied, by the distributors or representatives for the Gold Probe™, except the expressed warranty against defects described above. There will be no applicable warranty in the event of breakage resulting from thermal or mechanical shock. Additionally there will be no applicable warranty for a probe that has been subject to misuse, negligence or accident.**
- **For sensors operating at elevated temperatures, the warranty period is prorated such that full warranty is granted for operation below 1850°F (1010°C); six months warranty for temperatures between 1850°F (1010°C) and 1950°F (1065°C); three months warranty between 1950°F (1065°C) and 2050°F (1121°C), and no warranty above 2050°F (1121°C).**
- **This warranty cannot be honored unless the Registration Card is received at SSi prior to the Warranty Claim Report, and the use and installation is accomplished according to the techniques and procedures described in the Gold Probe™ Manual. SSi shall in no way be liable for special or consequential damages related to the use of this sensor.**

We suggest that you use this space to keep a record of installation date, test data and experiences with your **Gold Probe™**.

**NOTES**

**CARBON vs. DEW POINT WITH TEMPERATURE**

## GOLD PROBE MANUAL

%CO = 20.0 %H2 = 40.0 Af = 1.00 **Note: Dewpoint shown in degrees Farenheit.**

TEMP → % C ↓	1450F (788C)	1475F (802C)	1500F (815C)	1525F (829C)	1550F (843C)	1575F (857C)	1600F (871C)	1625F (885C)	1650F (899C)	1675F (913C)	1700F (927C)	1725F (940C)	1750F (954C)
0.05	142	137	133	129	124	120	117	113	109	106	103	99	96
0.10	117	113	108	104	101	97	94	90	87	84	81	78	75
0.15	103	99	95	91	88	84	81	77	74	71	68	66	63
0.20	93	89	86	82	78	75	72	69	66	63	60	57	55
0.25	86	82	78	75	71	68	65	62	59	56	53	51	48
0.30	80	76	73	69	66	63	60	57	54	51	48	46	43
0.35	75	71	68	64	61	58	55	52	49	46	44	41	39
0.40	71	67	64	60	57	54	51	48	45	43	40	37	35
0.45	67	63	60	57	53	50	47	45	42	39	37	34	32
0.50	64	60	57	53	50	47	44	41	39	36	34	31	29
0.55	60	57	54	50	47	44	41	39	36	33	31	28	26
0.60	58	54	51	48	45	42	39	36	33	31	28	26	24
0.65	55	52	48	45	42	39	36	34	31	28	26	24	21
0.70	53	49	46	43	40	37	34	31	29	26	24	21	19
0.75	50	47	44	41	38	35	32	29	27	24	22	19	17
0.80	48	45	42	39	36	33	30	27	25	22	20	18	15
0.85	46	43	40	37	34	31	28	25	23	20	18	16	14
0.90	44	41	38	35	32	29	26	24	21	19	16	14	12
0.95	42	39	36	33	30	27	25	22	19	17	15	12	10
1.00	41	37	34	31	28	26	23	20	18	15	13	11	9
1.05	39	36	33	30	27	24	21	19	16	14	12	9	7
1.10	37	34	31	28	25	22	20	17	15	12	10	8	6
1.15	36	32	29	26	24	21	18	16	13	11	9	6	4
1.20	34	31	28	25	22	19	17	14	12	10	7	5	3
1.25	33	29	26	24	21	18	15	13	11	8	6	4	2
1.30	31	28	25	22	19	17	14	12	9	7	5	2	0
1.35	30	27	24	21	18	15	13	10	8	6	3	1	-1
1.40	28	25	22	19	17	14	11	9	7	4	2	0	-2
1.45	27	24	21	18	15	13	10	8	5	3	1	-1	-3
1.50	26	23	20	17	14	11	9	7	4	2	0	-2	-5

Compliments of Super Systems, Inc., Cincinnati, OH 45249 800-666-4330

For use with SSi Models DP2000 and DPC2500

## CARBON vs. MILLIVOLTS WITH TEMPERATURE

GOLD PROBE MANUAL

%CO= 20.0 Note: Dewpoint shown in degrees Farenheit

TEMP → % C ↓	1450F (788C)	1475F (802C)	1500F (815C)	1525F (829C)	1550F (843C)	1575F (857C)	1600F (871C)	1625F (885C)	1650F (899C)	1675F (913C)	1700F (927C)	1725F (940C)	1750F (954C)
0.05	961	963	965	967	968	970	972	974	976	978	979	981	983
0.10	993	996	998	1000	1002	1005	1007	1009	1011	1014	1016	1018	1020
0.15	1012	1015	1018	1020	1023	1025	1028	1030	1033	1035	1038	1040	1043
0.20	1026	1029	1032	1034	1037	1040	1042	1045	1048	1050	1053	1056	1059
0.25	1037	1040	1043	1046	1048	1051	1054	1057	1060	1063	1065	1068	1071
0.30	1046	1049	1052	1055	1058	1061	1064	1067	1070	1073	1076	1078	1081
0.35	1054	1057	1060	1063	1066	1069	1072	1075	1078	1081	1084	1087	1090
0.40	1061	1064	1067	1070	1073	1076	1079	1082	1086	1089	1092	1095	1098
0.45	1067	1070	1073	1076	1079	1083	1086	1089	1092	1096	1099	1102	1105
0.50	1072	1075	1079	1082	1085	1089	1092	1095	1098	1102	1105	1108	1112
0.55	1077	1080	1084	1087	1091	1094	1097	1101	1104	1107	1111	1114	1117
0.60	1082	1085	1089	1092	1095	1099	1102	1106	1109	1113	1116	1119	1123
0.65	1086	1090	1093	1097	1100	1104	1107	1110	1114	1117	1121	1124	1128
0.70	1090	1094	1097	1101	1104	1108	1111	1115	1119	1122	1126	1129	1133
0.75	1094	1098	1101	1105	1108	1112	1116	1119	1123	1126	1130	1134	1137
0.80	1098	1102	1105	1109	1112	1116	1120	1123	1127	1131	1134	1138	1141
0.85	1101	1105	1109	1112	1116	1120	1123	1127	1131	1134	1138	1142	1146
0.90	1105	1109	1112	1116	1120	1123	1127	1131	1135	1138	1142	1146	1149
0.95	<i>1108</i>	1112	1116	1119	1123	1127	1131	1134	1138	1142	1146	1149	1153
1.00	<i>1111</i>	<i>1115</i>	1119	1123	1126	1130	1134	1138	1142	1145	1149	1153	1157
1.05	<i>1114</i>	<i>1118</i>	<i>1122</i>	<i>1126</i>	1130	1133	1137	1141	1145	1149	1153	1157	1160
1.10	<i>1117</i>	<i>1121</i>	<i>1125</i>	<i>1129</i>	<i>1133</i>	<i>1137</i>	1141	1144	1148	1152	1156	1160	1164
1.15	<i>1120</i>	<i>1124</i>	<i>1128</i>	<i>1132</i>	<i>1136</i>	<i>1140</i>	<i>1144</i>	1148	1151	1155	1159	1163	1167
1.20	<i>1123</i>	<i>1127</i>	<i>1131</i>	<i>1135</i>	<i>1139</i>	<i>1143</i>	<i>1147</i>	<i>1151</i>	1155	1159	1162	1166	1170
1.25	<i>1126</i>	<i>1130</i>	<i>1134</i>	<i>1138</i>	<i>1142</i>	<i>1146</i>	<i>1150</i>	<i>1154</i>	<i>1158</i>	<i>1162</i>	1166	1170	1174
1.30	<i>1128</i>	<i>1132</i>	<i>1136</i>	<i>1140</i>	<i>1144</i>	<i>1149</i>	<i>1153</i>	<i>1157</i>	<i>1161</i>	<i>1165</i>	<i>1169</i>	1173	1177
1.35	<i>1131</i>	<i>1135</i>	<i>1139</i>	<i>1143</i>	<i>1147</i>	<i>1151</i>	<i>1155</i>	<i>1159</i>	<i>1164</i>	<i>1168</i>	<i>1172</i>	<i>1176</i>	<i>1180</i>
1.40	<i>1134</i>	<i>1138</i>	<i>1142</i>	<i>1146</i>	<i>1150</i>	<i>1154</i>	<i>1158</i>	<i>1162</i>	<i>1166</i>	<i>1171</i>	<i>1175</i>	<i>1179</i>	<i>1183</i>
1.45	<i>1136</i>	<i>1140</i>	<i>1144</i>	<i>1149</i>	<i>1153</i>	<i>1157</i>	<i>1161</i>	<i>1165</i>	<i>1169</i>	<i>1173</i>	<i>1178</i>	<i>1182</i>	<i>1186</i>
1.50	<i>1139</i>	<i>1143</i>	<i>1147</i>	<i>1151</i>	<i>1155</i>	<i>1160</i>	<i>1164</i>	<i>1168</i>	<i>1172</i>	<i>1176</i>	<i>1180</i>	<i>1185</i>	<i>1189</i>

COMPLIMENTS OF SUPER SYSTEMS INC., CINCINNATI, OH 45249 800-666-4330

Note: mV values in italic bold correspond to saturation limits of carbon in steel



Revision	Description	Date
4501_A	Initial release	7/1/2005
4501_B	burnoff procedure corrected	6/23/2011

**SSi** SUPER SYSTEMS INC.

7205 Edington Drive Cincinnati, Ohio 45249  
1-513-772-0060 1-800-666-4330 FAX 1-513-772-9466