



SuperSystems
incorporated

HP15-VR Self-Heated Oxygen Measurement and Control System USER'S MANUAL

Super Systems Inc.
7205 Edington Drive
Cincinnati, OH 45249
Ph : 513-772-0060, 800-666-4330
Fax: 513-772-9466
www.supersystems.com

Table of Contents

Table of Contents.....	2
Overview	4
Electrical Connections	5
Dimensional Drawing	8
Spare Parts	12
Plumbing Connections	12
HP15-VR Screens	13
Main Overview Screen.....	13
Menu Screens	13
System Information	15
Logs.....	15
Alarm Log	15
System Log.....	15
Shut down interface.....	15
Burnoff	16
Slave Communications Status	16
Auxiliary Analog Input.....	16
PID Loop Setup	17
Burnoff Setup	19
Relay Assignments.....	20
Redundant Probe Setup	20
Communications Setup.....	21
Furnace Setup	23
Instrument Assignments.....	25
Temperature Instruments	26
Event Instruments	26
Analog Input Setup	26
Analog Output Setup.....	28
Alarm Setup	30
Aux Analog Input Setup.....	32
Overview	32
Equipment needed.....	33
Calibration Procedure	33
Input - Zero Calibration	33
Input - Span Calibration	34
Cold Junction	34
Calibration.....	34
Overview	34
Equipment needed.....	35
Calibration Procedure	35
Input - Zero Calibration	35
Input - Span Calibration	35
Output - Zero Calibration	36
Output - Span Calibration.....	36
Cold Junction	36

Tuning Assistant	37
Configuration.....	38
Edit Event Text	38
Compact Database.....	38
Communications Setup	39
Read/Write Data	39
Edit Trend Charts	40
Edit Datalogger	41
Reset Datalogger.....	42
Display	42
Return	42
Chart Screen	43
CO Factor	44

Overview

The HP15-VR system includes two main enclosures. The first contains the heater and the Gold Probe and is painted with a heat resistant black paint. This will be referred to as the “heater enclosure.” The second is the blue electrical control panel which includes a Super Systems 9120 controller. This will be referred to as the “electrical enclosure.” Proper operation of this system requires that these two enclosures be wired to each other, allowing the heater to be controlled by the electrical enclosure. For detailed information regarding the connections between the enclosures, please refer to the Electrical Connections section of this manual on the next page.



Electrical Connections

Insert the probe into the coupling at the base of the large box. **It is important that the probe is inserted at the correct depth to allow proper heating.** There should be between 10.0" and 10.5" between the bottom of the adjustable 1" NPT gland and the end of the probe (see sketch below).

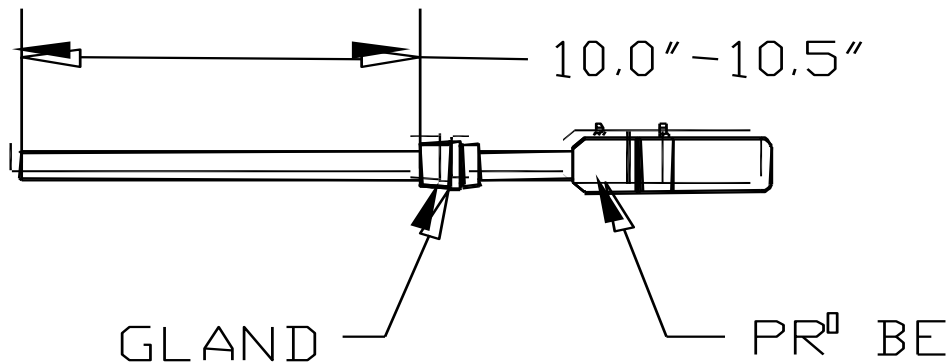

Once the probe has been inserted into the heater, make the necessary electrical connections at the head of the probe. Attach the green thermocouple wire from the electrical enclosure box to the thermocouple connection at the head of the probe (Positive (+) = Black; Negative (-) = Red). The sensor wire should also be attached to the probe (Positive (+) = Black; Negative (-) = White).

This unit has been pre-configured and tested prior to shipment. To maximize the accuracy and longevity of the Heated Probe, it is recommended that the unit be operated at 1500°F. It is also possible to configure the HP to match the temperature of your furnace.

Inside Electrical Enclosure

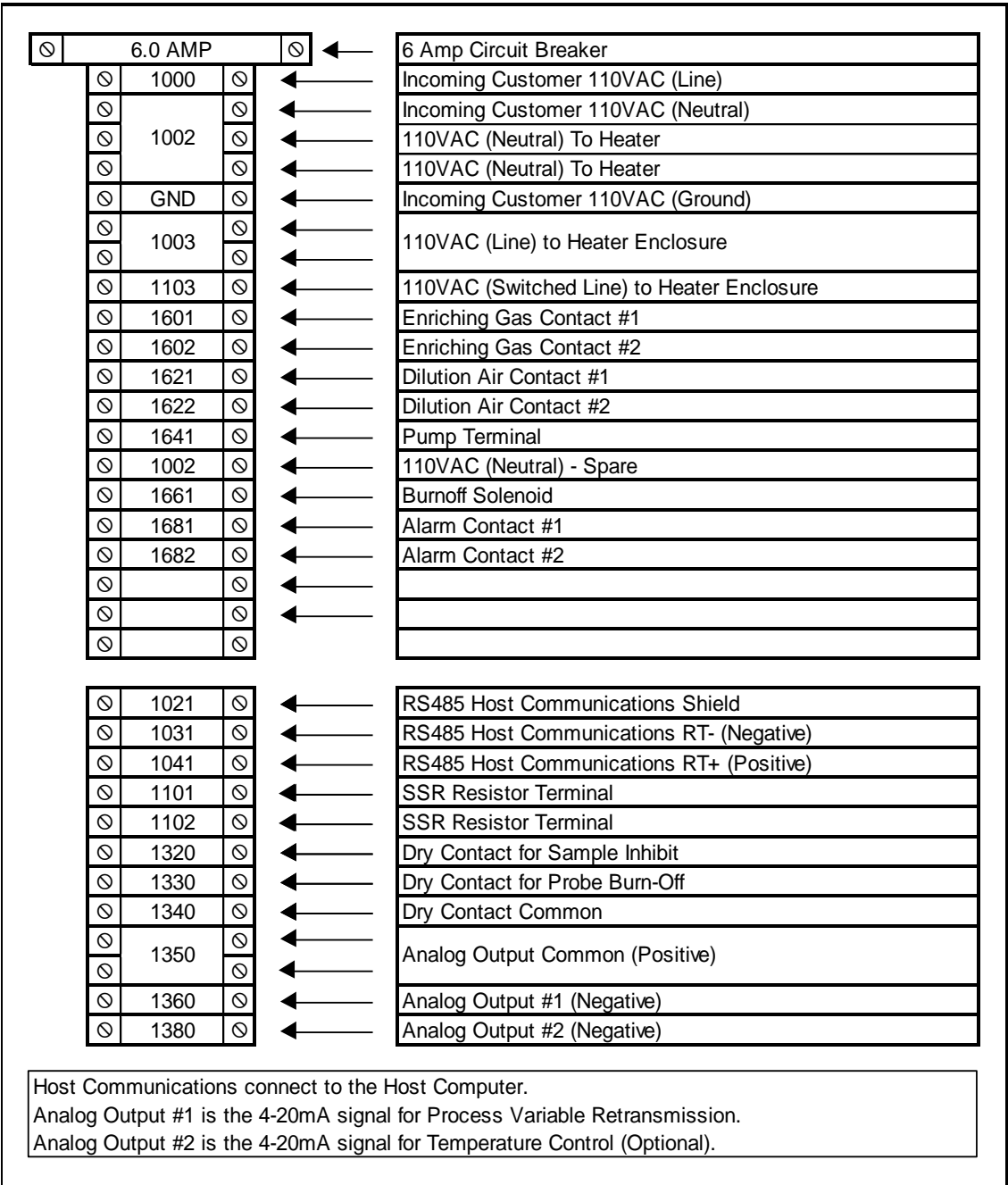

Inside Heater Enclosure

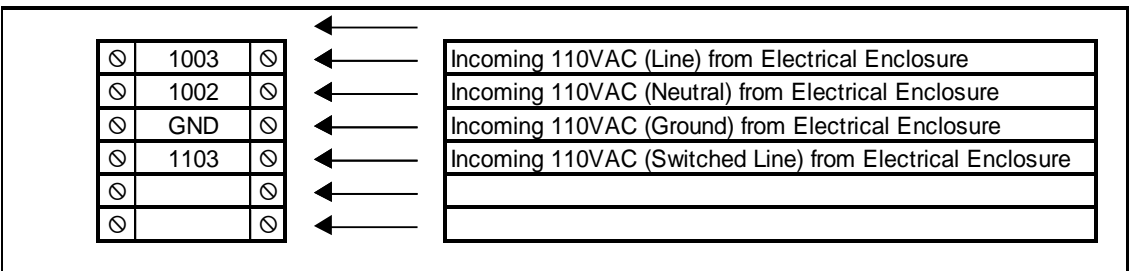

1. Connect incoming 120VAC to the Electrical Enclosure:

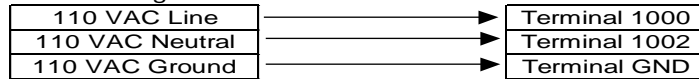

2. Connect Electrical Enclosure to Heater Enclosure:

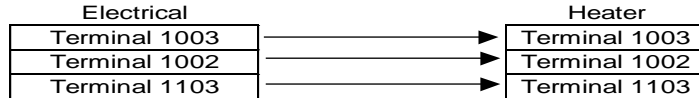

3. Connect "S" Type Thermocouple wire from Probe to Model 9120 Controller in Electrical Enclosure

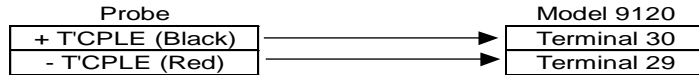

4. Connect Millivolt wire from Probe to Model 9120 Controller in Electrical Enclosure

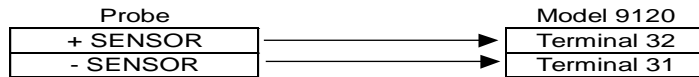

5. **(Optional)** Connect Furnace Thermocouple to Model 9120 Controller in Electrical Enclosure

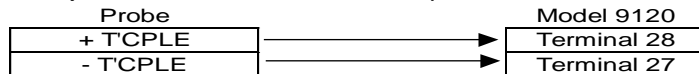

6. **(Optional)** Connect RS485 Communications to Host Computer

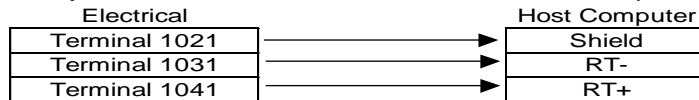

7. **(Optional)** Connect Enriching Gas Contact

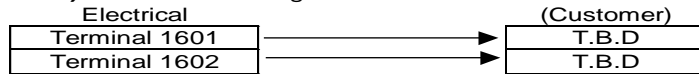

8. **(Optional)** Connect Dilution Air Contact

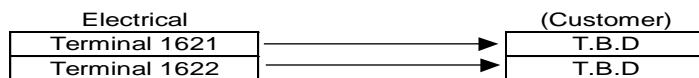

9. **(Optional)** Connect Alarm Contact

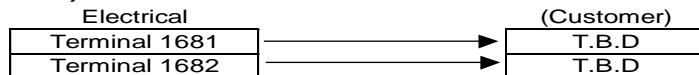

10. **(Optional)** Connect Dry Contact for Sample Inhibit

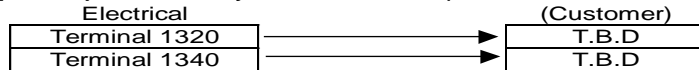

11. **(Optional)** Connect Dry Contact for Probe Burnoff

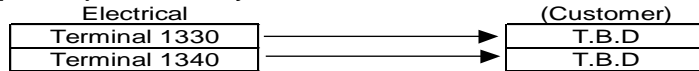

12. **(Optional)** 4-20mA Output for Process Variable Retransmission

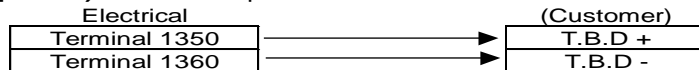

13. **(Optional)** 4-20mA Output for Temperature Control



Dimensional Drawing

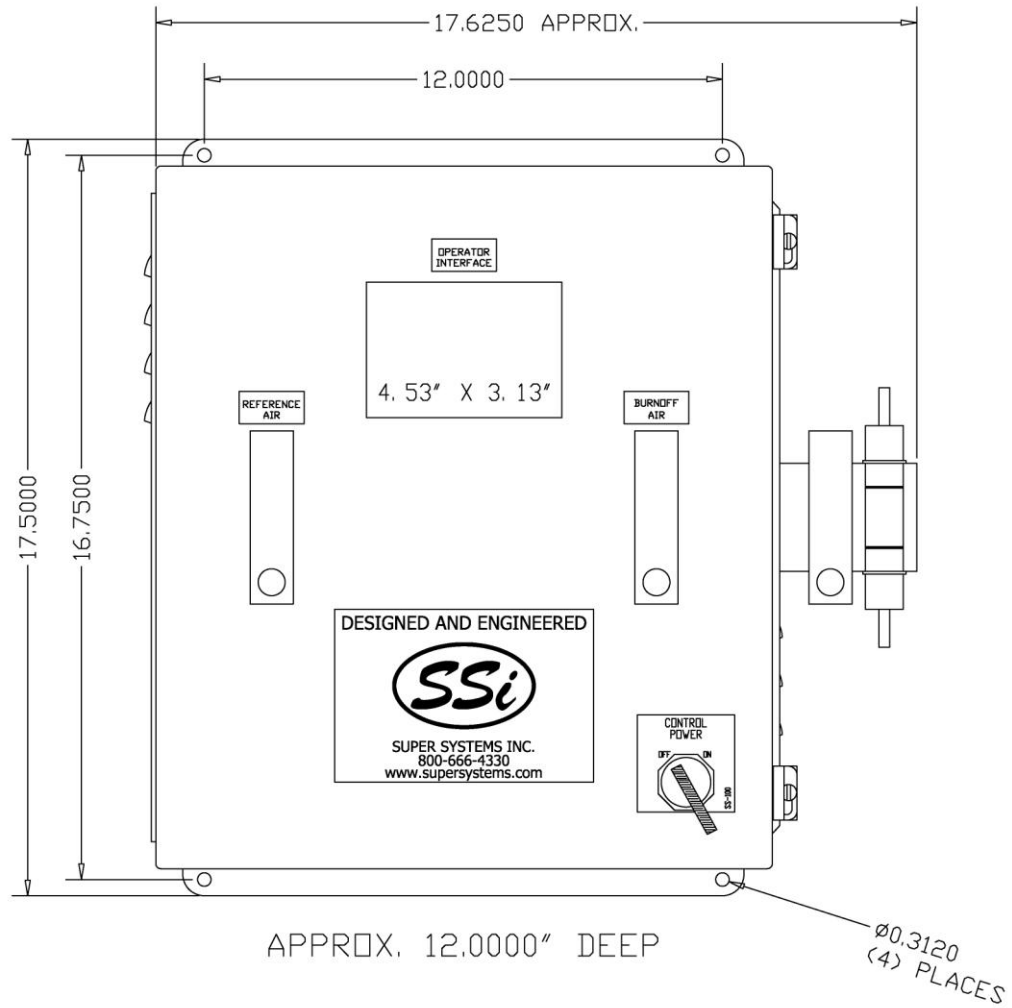

07-26-2011 9:48:03 AM

Dimensional Drawing of HP15-VR Electrical Enclosure

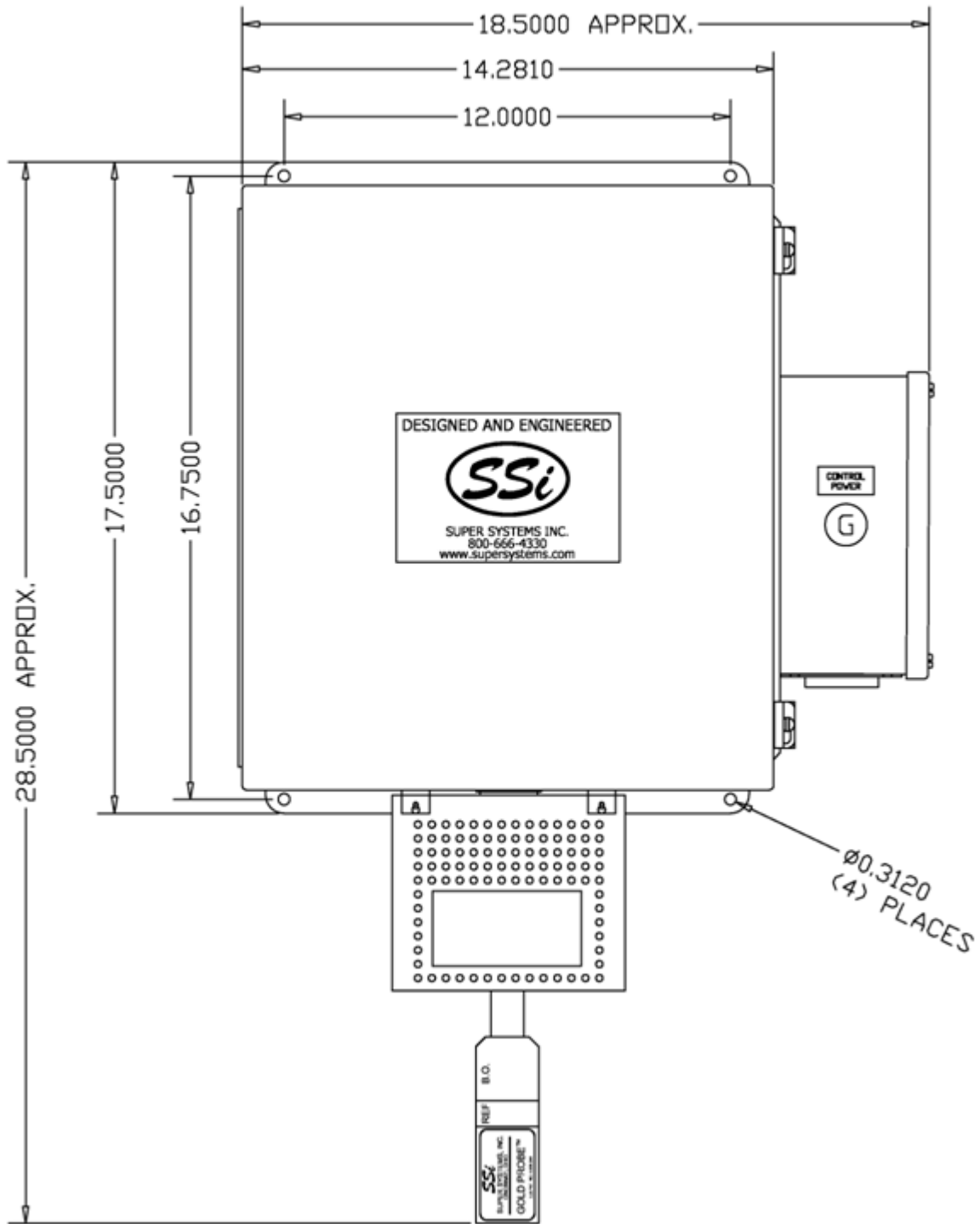

Dimensional Drawing of HP15-VR Heater Enclosure with Sensor Inserted

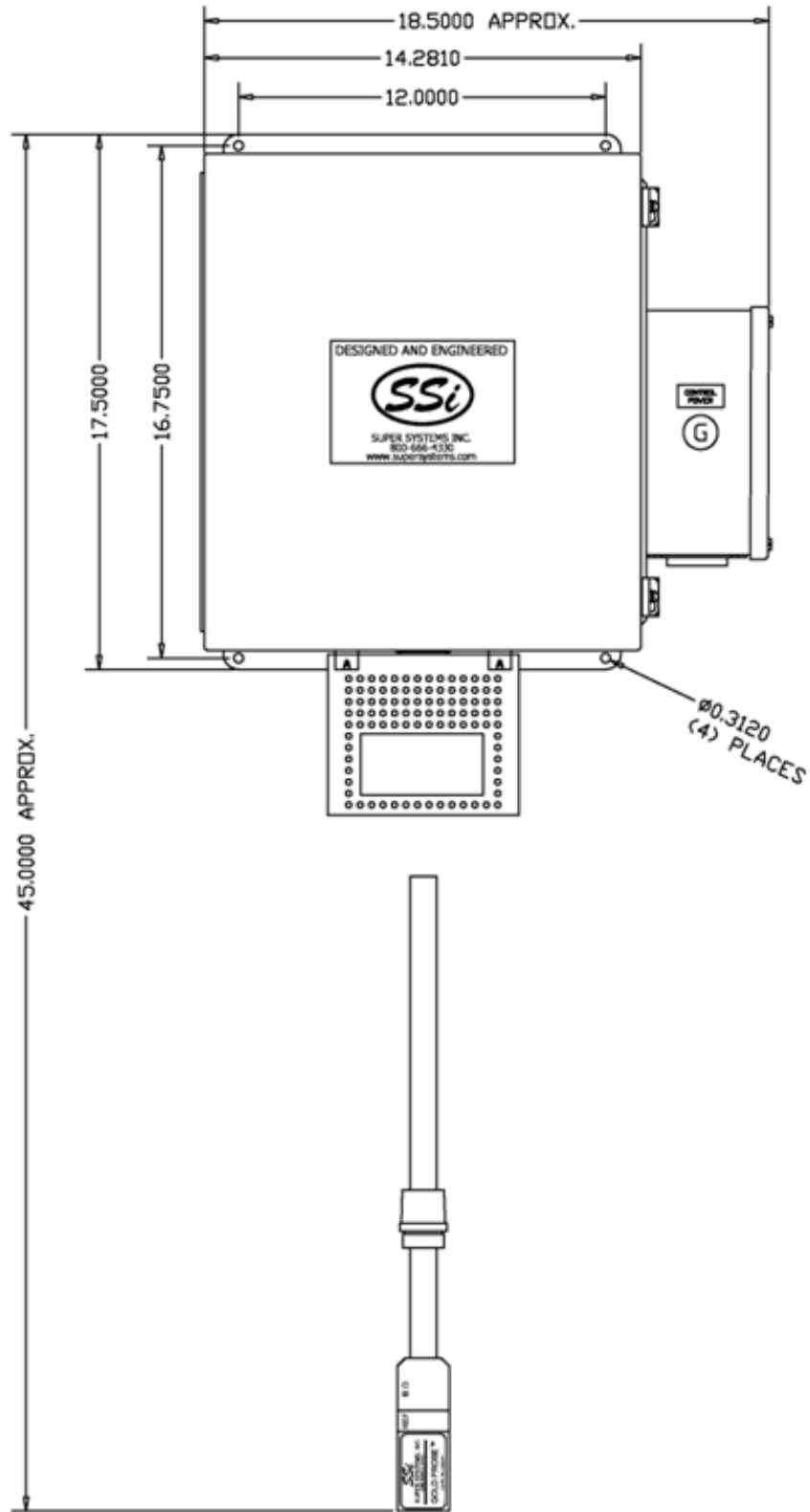

Dimensional Drawing of HP15-VR Heater Enclosure with Sensor Removed

Spare Parts

The following is a list of spare parts recommended for the HP15-VR.

P/N	Description
20401	Ceramic Heater/Well Spacers
31080	7EK Temperature Controller
31096	Controller, Overtemp
31125	Power Supply 24V DC
32074	Heater
32122	SSR, 10A 240V Low Profile
37120	Pump - Reference Air
37138	Valve, Solenoid, 3-Way
37177	Pump - Sample / Burnoff Air
13454	Series 9120 Controller
36013	Flowmeter, 0.2 to 2 SCFH
36027	Flowmeter, 0.5 to 5 SCFH
36017	Flowmeter, 1 to 10 SCFH
31604	SD Flash Card
13498	3.5" Color Touch Screen
20059	Filter with Glass Wool Media
37037	Filter media replacement (20 grams)

Plumbing Connections

The sample gas is transported from the furnace to the electrical enclosure filter using silicone tubing. The sample flow should be between 4.0 and 5.0 SCFH. Connect the ports on the side of

the electrical enclosure to the probe in the heater enclosure using silicone tubing. Connect tubing from the fitting on the electrical enclosure marked "To Probe Reference" to the "Ref. Air" port on the probe. A connection should also be made between the "To Burnoff Port" fitting and the "B.O." fitting on the probe. There is a barb fitting on the stainless steel well on the heated probe. This is the vent, which needs to be routed to an appropriately safe location.

HP15-VR Screens

Main Overview Screen

The Main Overview screen will be the initial screen that is displayed when the Touchscreen is started. The Main Overview screen will display the following for each loop: type, setpoint, current value, output mode, output, the activated/deactivated inputs and outputs, any messages, the **Menu** button, **Chart** button and **CO Factor** button. Any activated inputs or outputs will be lit up. Note on Inputs and Outputs – The numbering on the display starts at 0 instead of 1, so input 2 shown in the figure is actually input 3, and output 4 is actually output 5. The red bar will display any messages. The output mode can be changed from auto to manual by pressing the auto/manual button to toggle between the two options.



The top of the screen displays the point value type (PVT) of %Carbon with Temperature control. In the example figure, the %Carbon column shows the calculated %Carbon of 1.8% and the setpoint of 1.00%. The Temperature column shows the measured temperature of 1502°F and the setpoint of 1531°F. The PVT can be Oxygen, Carbon, Dewpoint, or millivolts.

There are three active buttons at the bottom of the screen: **Menu**, **Chart**, and **CO Factor**.

Menu Screens

The menu screen will allow the user to configure the 9120 unit based on the login level. When the menu list is first displayed, the user will be automatically logged in at the Operator-level. The number of menus will vary based on the login level. The default login for Supervisor is a 1. The default login for Administrator is 2.

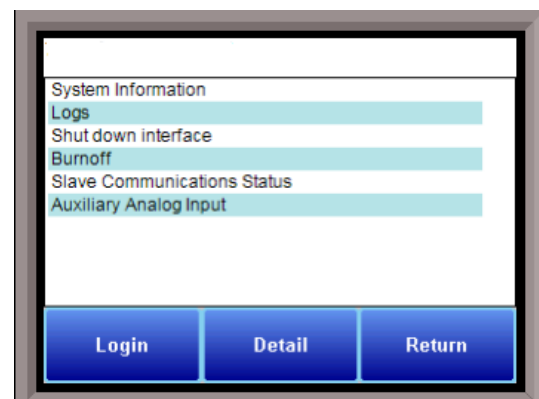

The Operator-level will have the following menu items:

- System Information
- Logs

- Shut down interface
- Burnoff
- Slave Communications Status
- Auxiliary Analog Input

The Supervisor-level will have the following menu items:

- System Information
- Logs
- Shut down interface
- Burnoff
- Slave Communications Status
- Auxiliary Analog Input
- PID Loop Setup
- Burnoff Setup
- Relay Assignments
- Redundant Probe Setup

The Administrator-level will have the following items:

- System Information
- Logs
- Shut down interface
- Burnoff
- Slave Communications Status
- Auxiliary Analog Input
- PID Loop Setup
- Burnoff Setup
- Relay Assignments
- Redundant Probe Setup
- Communications Setup
- Furnace Setup
- Instrument Assignments
- Analog Input Setup
- Analog Output Setup
- Alarm Setup
- Aux Analog Input Setup
- Calibration
- Tuning Assistant
- Configuration

There is also an SSi-special-level that can only be accessed with the passcode that can be provided by Super Systems Inc at 800-666-4330. Currently, the menu list for this level is the same as the list for the Administrator-level. To select a menu item, highlight the item by clicking on it and pressing the **Detail** button. The **Login** button will allow the user to login as a different access level. The **Return** button will allow the user to return to the main screen.

System Information



This screen will display general system information about the 9120 Touchscreen. This screen will be useful for troubleshooting when communicating with an SSI representative. This screen will display the 9120 instrument's version number, the Touchscreen software's version number, SSI's phone number, and a link to the SSI website.

Logs

The two types of logs available are System Log and Alarm Log. To toggle between these two options, press the **System Log/Alarm Log** button at the top of the logs screen.

Alarm Log

This screen will display a record of alarms. To change the date that you are viewing, use the green arrows or the drop down menu from the date. Press **Return** to go back to the Menu.

System Log

This screen will display a record of any startup and shutdowns as well as any operator interface issues. To change the date that you are viewing, use the green arrows or the drop down menu from the date. Press **Return** to go back to the Menu.

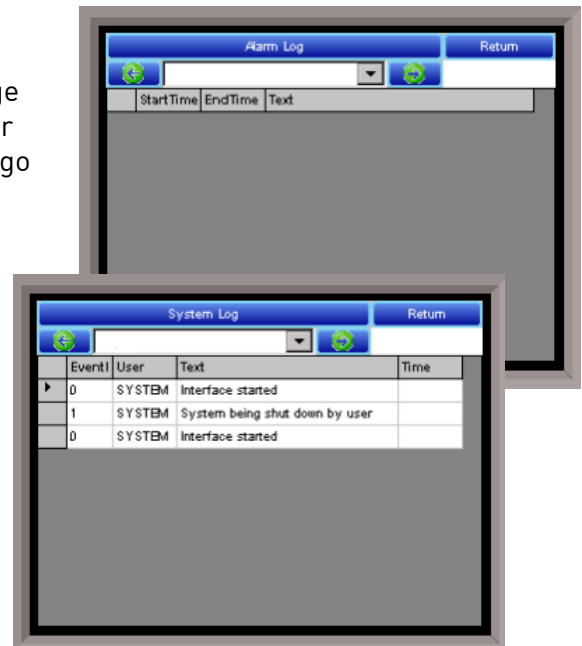

Shut down interface

This option will shut down the 9120 unit interface. This option should be used before turning off the power to the 9120 unit to verify that all the information has been saved. The user will need to verify the shutdown process. Once the interface has been shut down, it can be restored simply by cycling power to the unit, or by pressing the reboot button on the screen, circled in red on the picture.

Burnoff

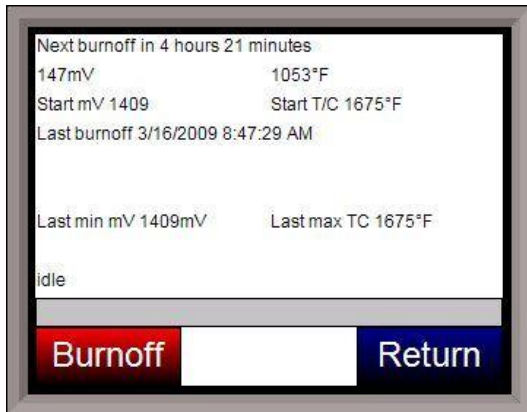

When a probe is in a furnace, soot will collect in the end of the probe, which will have a negative effect on the performance of the probe. Burnoffs are used to clean out the built-up carbon by burning it off of the probe. This screen will display: the current millivolts, T/C temperature reading, the start millivolts and start T/C temperature reading, the date of the last burnoff, the last minimum millivolts reading, and the last maximum T/C temperature reading. The last line will display the status of the burnoff. The options can be: Burnoff, Burnoff Recovery, or Idle. The

burnoff settings can be modified in the Burnoff Setup menu option.

Slave Communications Status

This page is a display of the current process variables of each of the slave instruments communicating with the 9120 controller. Note – None of these values can be modified on this screen. The slave instruments can be set up in the Instrument Assignments menu option. A **[N/A]** displayed means that the slave instrument has not been set up yet. A **Bad** means that communications are not functioning properly or that the instrument has been set up improperly. Note: Twenty-five (25) slave instrument statuses will be displayed on this screen.



Auxiliary Analog Input

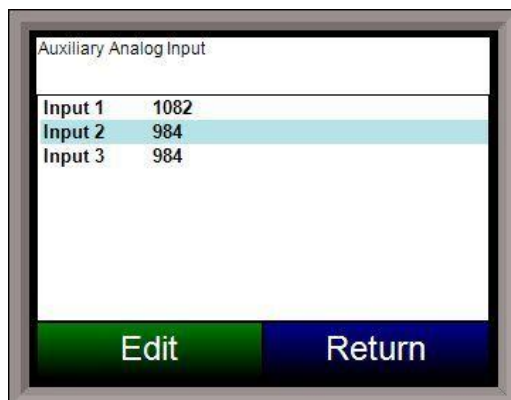

This menu option shows the process variables for the auxiliary analog inputs of the 9120 controller. Note – None of these values can be modified on this screen. The auxiliary analog inputs can be set up in the Aux Analog Input Setup menu option.

PID Loop Setup

PID is the tuning parameters entered for each Process Variable loop.

Prop Band (0 for On/Off)

This is the proportional band field. This represents the P in PID. P = Proportional. This is a field in which you want the process variable to stay around the setpoint. Clicking on the value will allow the user to change the value. The range for the proportional band value is **0 – 9999.0**.

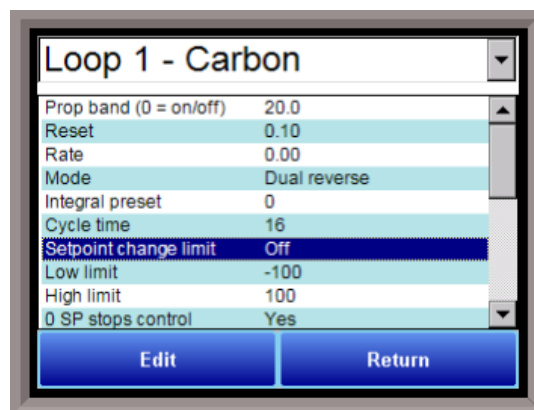

Reset

This is the reset field. This represents the I in PID. I = Integral. This is the actual temperature being monitored over a period of time and then averaged to keep within the Proportional band. The reset is in repeats per minute. This helps to eliminate offset. Clicking on the value will allow the user to change the value. The reset range **0 – 10000.00**.

Rate

This is the rate field. This represents the D in PID. D = Derivative. This is the sudden change or rate in the temperature. This rate is in minutes. This affects the controller output which is proportional to the rate of change of the measurement and will control the amount of output by time restraints. Thus derivative takes action to inhibit more rapid changes of the measurement than proportional action. Derivative is often used to avoid overshoot. Clicking on the value will allow the user to change the value. The range for the rate is **0 – 10000.00**. The rate is not typically used for heating/carbon.

Mode

This is the mode of the loop. Clicking on the value will allow the user to change the value. The following is an explanation of the dual/single and direct/reverse properties:

Dual – This has two output relays which can increase and decrease to achieve your SP.

Single – This has one relay which works in only one direction to achieve your SP.

Direct - If the PV - SP is a positive number and the output would bring the PV down toward setpoint, then that is direct.

Reverse – If the PV - SP is a negative number and the output would bring the PV up toward setpoint, then that is reverse

Example: If a 12 mA output drives a 0 degree F temp. (PV) up to a 1200 degree F temp. (SP), this would be REVERSE, and since this would take a SINGLE output from the controller, the Mode for the Temperature Loop is Single Reverse.

The mode values can be:

Dual Reverse

Single Reverse

Dual Direct

Single Direct

Integral Preset

This field provides an offset for the starting point for PID control, also referred to as “Load Line” or “Manual Reset”. Clicking on the value will allow the user to change the value. The range for the integral preset is **-100 to 100**.

Cycle Time

Clicking on the value will allow the user to change the value. This field is typically set to the valve travel time multiplied by 1.5. The cycle time range can be **0 – 500**.

Setpoint Change Limit

This is a smart time feature that allows the Process Loop to use PB only without Reset until the Process Variable drops below the percent output set under this category.

It is used to eliminate overshoot.

The Output percentage selected under this category **must** be above the normal operating output percentage of the furnace at heat.

Clicking on the value will allow the user to change the value.

Example – if the furnace runs at 40% output at heat for the maximum load, the setpoint change limit should be set to 60%.

The value can be:

OFF

80 %

70 %

60 %

50 %

40 %

30 %

20 %

Low Limit

This is the low limit field. Clicking on the value will allow the user to change the value. The range is **-100 to 100**.

High Limit

This is the high limit field. Clicking on the value will allow the user to change the value. The range is **-100 to 100**.

0 Setpoint Stops Control

If the Setpoint is zero, then all outputs are turned off. Clicking on the value will allow the user to change the value. The option is either **Yes** or **No**.

IN1 high stops control

If input 1’s high limit is reached, then all outputs are turned off. The value can either be **Yes** or **No**.

IN2 high stops control

If input 2’s high limit is reached, then all outputs are turned off. The value can either be **Yes** or **No**.

IN3 high stops control

If input 3's high limit is reached, then all outputs are turned off. The value can either be **Yes** or **No**.

PID Auto Switch

This is the PID auto switch field. The value can either be **Yes** or **No**.

Switch Point PID 1 -> 2

This is the PID Switch Point field. The range is **-500** to **4000**.

Switch Point PID 2 -> 3

This is the PID Switch Point field. The range is **-500** to **4000**.

Overshoot Limit Gain

This is the Overshoot limit gain field. When calculating the control action sometimes the calculation would call for more than 100%, which is not possible. The output is limited to 100%, or whatever was set in the High Limit field. The difference of the unlimited minus the limited is multiplied by the overshoot limit gain and divided by 100. This is subtracted from the control output. If the gain is 0 there is no effect. Under normal control, the unlimited equals the limited and there is no effect. If there is a big change where the control loop drives hard, then the effect is to limit the drive as it approaches setpoint and limit the overshoot.

The limited is the values set in the upper and lower limits fields. The unlimited would be what is calculated before limiting. For a big setpoint change, the calculations may compute 150% output, but the true output is limited to the upper limit. The range is **0** to **9999**.

Setpoint Lower Limit

This is the setpoint lower limit for the loop. The range is **-500** to **4000**.

Setpoint Upper Limit

This is the setpoint upper limit for the loop. The range is **-500** to **4000**.

Use Input 3 as remote SP

This will allow the user to set the heater enclosure to match the temperature of the furnace.. The options are: **yes** or **no**.

Control Input

This will allow the user to view the input that will act as a control T/C. This setting is fixed and cannot be changed by the user.

Burnoff Setup

This menu option allows the user to modify the settings that are associated with the probe burnoff (menu option Burnoff).

Burnoff Time (sec)

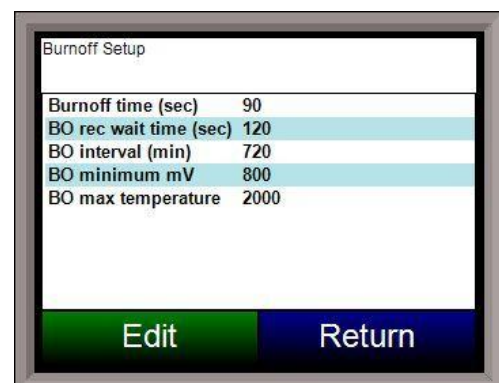

Burnoff Setup	
Burnoff time (sec)	90
BO rec wait time (sec)	120
BO interval (min)	720
BO minimum mV	800
BO max temperature	2000

At the bottom of the screen, there are two buttons: **Edit** (green) and **Return** (blue).

The amount of time from the beginning of the burnoff to the end of the burnoff measured in seconds. The range is 0 to 600.

Burnoff Recovery Wait Time (sec)

The amount of time allotted to allow the probe measurements to return to a stable, accurate range after the burnoff is complete. This is measured in seconds. The control output is held until this time is elapsed. The range is 0 to 300.

Burnoff Interval (min)

The amount of time between the beginning of one burnoff and the beginning of the next scheduled burnoff measured in minutes. The range is 0 to 10080.

Burnoff Minimum Millivolts

The minimum measured millivolt tolerance of the probe required to start a burnoff. If the millivolts value is exceeded the burnoff will stop. This is done to help maintain the life and the accuracy of your probe. The range is 0 to 2000.

Burnoff Maximum Temperature

The maximum measured temperature allowed during a burnoff. If the temperature value is exceeded the burnoff will stop. This is done to help maintain the life and the accuracy of your probe. The range is 0 to 4000.

Relay Assignments

This screen will display a description of the eight relay assignments. The eight “Outputs” on the front of the unit represent the eight relay assignments, where Output #1 = Relay Assignment 1, etc. Most of the relay assignments are fixed in the unit. Relay 1 is the loop 2 control relay. Relay 2 is the input 2 high limit relay. Relay 3 is the loop 1 increase relay. Relay 4 is the loop 1 decrease relay. Relay 6 is the probe burnoff relay. Relay 8 is the any alarm relay. Relay 7 is the only relay that can be assigned.

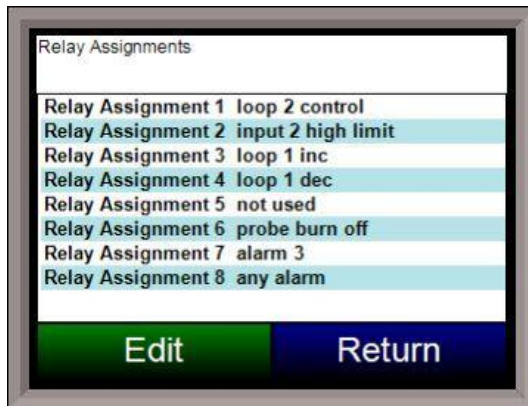

Redundant Probe Setup

This menu option will allow the user to configure the 9120 for RPS functionality.

Alarm band (mV)

This is the millivolt difference that must be observed for the RPS to change probes. For example, when the RPS is selecting the highest probe with probe 1 as 1055 mV and a band of 20 mV, and if probe 2 hits 1076 mV, the

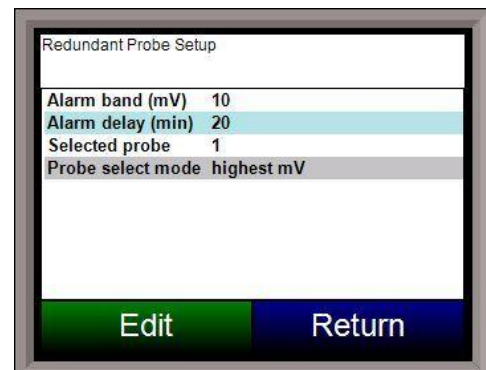

RPS will start counting down the Alarm Delay timer (below). When the delay times out, probe 2 would be selected. If probe 2 comes back in band (drops to 1075), the timers starts over again. The range is **0** to **600**.

Alarm delay (min)

This is the number of minutes that the RPS waits to switch probes when an out-of-band condition is detected. Note - There is a 950 mV low limit for an alarm. This condition is typically found during a burnoff, so the alarm will not be active when the input drops below 950 mV. The range is **0** to **9999**.

Selected Probe

Indicates which probe is selected. Note – This field is only editable when the Probe select mode (below) is set to no auto switch. The options are: **0** or **1**. Note – The number of the probe is 0-based, so “0” = probe 1 and “1” = probe 2.

Probe select mode

This determines how the specified probe is selected. The options are: **highest mV**, **lowest mV**, or **no auto switch** (manual mode).

Communications Setup

This menu option will allow the user to configure the communications settings for the 9120 unit. **It is strongly recommended that none of these settings be modified without assistance from Super Systems at 800-666-4330.**



RS-232B Baud

This will allow the user to set the RS-232B baud rate. **This must be set to 19200 for the Touchscreen.**

The options are:

1200	14400	57600
2400	19200	76800
4800	28800	115200
9600	38400	

RS232B Mode

This will allow the user to set the RS232B mode. Note – This must be set to Modbus for the Touchscreen. The options are: **Modbus master** or **Modbus**.

RS-232A Baud

This will allow the user to set the RS-232A baud rate. **This must be set to 19200 for the Touchscreen.** Note – This option is fixed at 19200 and is not currently used in the 9120 Touchscreen.

The options are:

1200	14400	57600
2400	19200	76800

4800	28800	115200
9600	38400	

RS232A Mode

This will allow the user to set the RS232A mode. **This must be set to Modbus for the Touchscreen.** The options are: **Modbus, Cal Term,** and **Televac.** Note – This option is fixed at 19200 and is not currently used in the 9120 Touchscreen.

Host 485 Baud

This will allow the user to set the Host 485 baud rate. **This must be set to 19200 for the Touchscreen.**

The options are:

1200	14400	57600
2400	19200	76800
4800	28800	115200
9600	38400	

Host 485 Mode

This will allow the user to set the Host 485 mode. **This setting is fixed to Modbus for the Touchscreen.**

Host 485 Address

This will allow the user to set the Host 485 address. The range is **0** to **249**.

Slave 1 Baud

This will allow the user to set the Slave 1 baud rate.

The options are:

1200	14400	57600
2400	19200	76800
4800	28800	115200
9600	38400	

Slave 1 Mode

This will allow the user to set the Slave 1 mode. The options are: **MMI, Modbus master, Yokogawa,** or **Modbus host.**

Slave 2 Baud

This will allow the user to set the Slave 2 baud rate.

The options are:

1200	14400	57600
2400	19200	76800
4800	28800	115200
9600	38400	

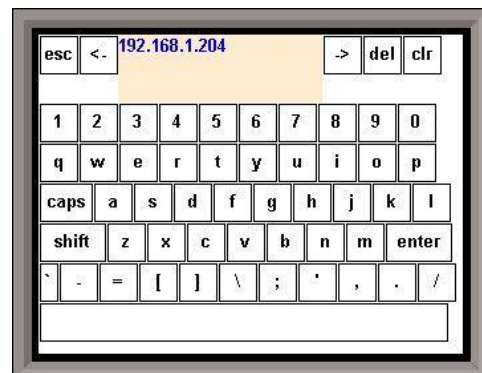

Slave 2 Mode

This will allow the user to set the Slave 2 mode. The options are: **MMI, Modbus, ADAM, SSI Analog Input Board, or Yokogawa.**

IP Address

This option will allow the user to modify the IP address of the 9120 Instrument only. The address must be supplied in a 999.999.999.999 format, or it will not be accepted. Contact Super Systems at 800-666-4330 or your IT department before changing any of the IP addresses. Note – Communications may go down once the IP address has been changed and before the rest of the settings, i.e. the Configuration menu → Communication Setup menu, have been updated.

Subnet Mask

This option will allow the user to modify the IP subnet mask of the 9120 Instrument only. The address must be supplied in a 999.999.999.999 format, or it will not be accepted. Contact Super Systems at 800-666-4330 or your IT department before changing any of the IP addresses.

Gateway

This option will allow the user to modify the IP gateway of the 9120 Instrument only. The address must be supplied in a 999.999.999.999 format, or it will not be accepted. Contact Super Systems at 800-666-4330 or your IT department before changing any of the IP addresses.

Furnace Setup

This screen will allow the user to configure the furnace settings. Do not make any adjustments on this screen without first contacting Super Systems Inc at 800-666-4330.

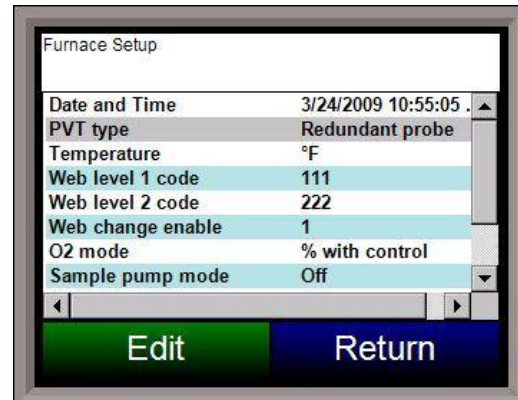

Date and Time

This option will allow the user to change the current date and time on the 9120 controller, not the touch screen. **The date and time that is recorded on the flash card (and, therefore, the datalog data) is the date and time of the operator interface display, not the 9120 instrument. To change the date and time of the touch screen, see Appendix B – Changing the Date/Time on the Touchscreen.** Note – The initial date and time displayed will be the system time of the Touchscreen, not the current time on the 9120 instrument.

PVT Type

The PVT type is the mode the device runs in (Carbon, Dewpoint, etc.). The mode selected determines the calculations and scaling for the Process Variable.

The values for the PVT type are:

Carbon

Dew Point

Oxygen

Millivolt

Redundant Probe

Simple Nitrider

Dual Loop

Temperature

This value determines the specific temperature scale to be used. Clicking on the value will allow the operator to change the value. It can be either Degrees °F or degrees °C.

Web Level 1 Code

This value is the supervisor-level passcode for any web-based operations with the 9120 controller. Clicking on the value will allow the operator to change the value. The range for the passcode is **-32767** to **32767**.

Web Level 2 Code

This value is the administrator-level passcode for any web-based operations with the 9120 controller. Clicking on the value will allow the operator to change the value. The range for the passcode is **-32767** to **32767**.

Web Change Enable

This will either enable or disable the web change feature, which will allow changes to be made over the web page for the 9120 controller. Clicking on the value will allow the operator to change the value. Select either a **0** (Web Change Disable) or a **1** (Web Change Enable).

O2 Mode

This value will allow the operator to select the oxygen mode. Clicking on the value will allow the operator to change the value.

The options are:

% with control

Monitor

Offset log with control

Sample Pump Mode

This menu option will allow the user to turn the sample pump **On** or **Off**. For the HP PVT types (**% Carbon**, **Dewpoint**, **Oxygen**, **Millivolt**, and **Redundant Probe**), there is the option to set a minimum temperature in order for the pump to run. See the “Minimum Temp/Pump Run” description below.

Minimum temp/pump run

This option will set the minimum temperature for the pump to run, if that feature is used. A **0** value will disable the minimum temperature feature. Note - The furnace that is being sampled must have its temperature connected to input 3 for the pump minimum temperature feature to work. The range is **0** to **32767**.

Remote Setpoint

This option will allow the user to select where the remote setpoint will come from. The options are:

None

Slave 1 PV

Slave 2 PV

Slave 1 SP

Slave 2 SP
Input 3

Remote Setpoint Hysteresis

This option will allow the user to enter the remote setpoint hysteresis. The range is **0** to **32767**.

Loop 2 PV source

This option will allow the user to select the loop 2 PV source. The options are: **Input 3** or **Input 2**.

Instrument Assignments

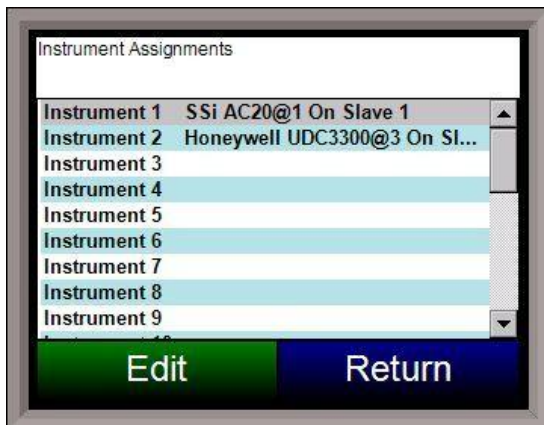

This menu option will allow the user to set up the slave instruments for the 9120.

** All devices on the same slave port must utilize the same protocol

** An address of zero (0) will disable the instrument**

Some controllers (AC20, for example) can provide dual functions (atmosphere and events) and must have the same address assigned for both.

Instruments

The 9120 unit breaks down the instruments into three different types: atmosphere, temperature, and event. Instrument 1 must be an atmosphere instrument, Instrument 2 must be a temperature instrument, and Instrument 3 must be an even instrument. The atmosphere instruments are listed with a blue background. The temperature instruments are listed with a pink background. The event instruments are listed with a yellow background. The following is the list of instruments available as slave instruments:

Atmosphere Instruments

SSi AC20
Yokogawa 750
Honeywell UDC3300
Dualpro LP1 Modbus
Dualpro LP2 Modbus
Dualpro LP1 MMI
Dualpro LP2 MMI
Eurotherm 2402
Eurotherm 2500
Cabpro v3.5
Cabpro v3.0
CarbPC
9200 LP1
IR Base

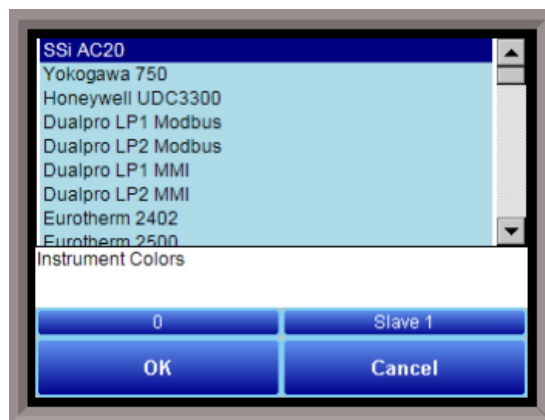

MGA

Temperature Instruments

SSi 7EK	9200 LP1	SSi Quad A01
Yokogawa 750	9200 LP2	SSi Quad A02
Honeywell UDC3300	9200 LP3	SSi Quad A03
Dualpro LP1 Modbus	9100 LP2	SSi Quad A04
Dualpro LP2 Modbus	Eurotherm 2704 LP1	Yokogawa UT350
Dualpro LP1 MMI	Eurotherm 2704 LP2	Yokogawa 750 Lp 2
Dualpro LP2 MMI	Eurotherm 2704 LP3	Yokogawa UP350
Eurotherm 2402	VC Base 1	Honeywell DCP551
Eurotherm 2500	VC Base 2	Ascon 08
Unipro v3.5	VC Base 3	
Unipro v3.0	VC Base 4	
Carbpro v3.5 Slave	AIPC	
Carbpro v3.0 Slave	SSi 7SL	
10Pro	AEC Flow Board	
Dualpro IN C	UMC800 LP1	

Event Instruments

SSi AC E
Yokogawa 750E
Mod Mux
Dualpro E Modbus
Dualpro E MMI
Carbpro E v3.5
Carbpro E v3.0
Eurotherm 2500
SSi 8-8
SSi 9200 E
Micrologix PLC
MCM Module
PLC5 DF1
SLC DF1

Address

This value allows the user to select the address that corresponds with the controller selected, with a range of 0 to 255.

Port

This is the port that the slave instrument will use. The options are: Slave 1 or Slave 2.

Slave 1 – terminals 5(-), 6(+)

Slave 2 – terminals 22(+), 23(-).

Analog Input Setup

The 9120 controller has two analog inputs. Each of the inputs comes with a factory default

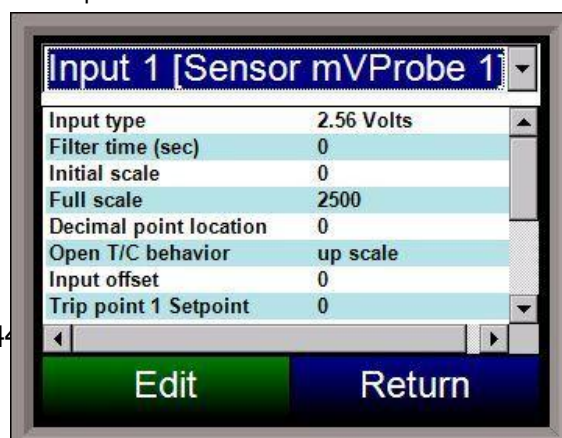

configuration dependent on the application (refer to PVT type under the Furnace Setup section). It can be modified prior to shipment to your facility or in the field by a technician or qualified/trained person with the proper security code.

Analog Input Terminals:

Analog Input 1 – terminals 31 and 32

Analog Input 2 – terminals 29 and 30

Input Type

The thermocouple type for most applications can be modified depending on your specific needs. Please note that in some applications, some of the inputs DO NOT allow the user to modify the Input type. Note - Before changing the input type, make sure to set the appropriate jumpers, if necessary. The jumper will need to be manually changed on the input board before changing the input type to a 10:1 setting (non-thermocouple types). To change the Input type, first select which input you want to change by selecting it in the pull-down menu at the top of the screen. Once selected, click OK and the displayed Input type under Value will be the current type.

The following is a list of the options:

T/C B	T/C S	12.5 volts ***
T/C C	T/C T	781.25mv
T/C E	2.56 volts	195.3125 mV
T/C J	1.28 volts	
T/C K	78.125 mV	
T/C N	19.53125 mV	
T/C NNM	4-20 mA ***	
T/C R	25 volts ***	

*** When the specified input type is selected, a jumper located inside the case will need to be placed on that specific input for reading this selection. If jumper is not placed on input, then damage could occur to the board. ***

Filter time

The filter time is a factory applied averaging tool used to help maintain steady control in high EMI environments. The filter time should not be adjusted with consulting SSI. The range is 0 to 32767.

Initial Scale

This is the initial scale value. Clicking on this value will display an input box from which the user can select a new value. This could also be referred to as the starting value. For example, the initial value is the value when 0 volts is on the selected input; or on a 4-20 mA input, it would be the value at the selected input of 4 mA. The range is -32768 to 32767.

Full scale

This is the full scale value. Clicking on this value will display an input box from which the user can select a new value. The range is -32768 to 32767.

Decimal Point Location

This is the decimal point location value. Clicking on this value will display an input box from which the user can select a new value. This will affect the PV value and the location of the decimal when it is displayed. The range is 0 to 4.

Open TC behavior

This is the open TC value. The options are: **up scale**, **down scale**, **one trip point**, or **two trip points**.

Input Offset

The input offset value is algebraically added to the input value to adjust the input curve on read-out. Note - The input offsets are unscaled. The range is **-32767** to **32767**.

Trip Point 1 Setpoint

This is the trip point 1 setpoint value. The range is **-32767** to **32767**.

Trip Point 1 Force Value

This is the trip point 1 force value. The range is **-32767** to **32767**.

Trip Point 1 Direction

This is the trip point 1 direction. The options are: **input above setpoint** or **input below setpoint**.

Trip Point 2 Setpoint

This is the trip point 2 setpoint value. The range is **-32767** to **32767**.

Trip Point 2 Force Value

This is the trip point 2 force value. The range is **-32767** to **32767**.

Trip Point 2 Direction

This is the trip point 2 direction. The options are: **input above setpoint** or **input below setpoint**.

High Input Limit Setpoint

This is the setpoint for the high input limit. The range for this can be **-32767** to **32767**.

High Input Limit Hysteresis

This is the hysteresis for the high input limit. The range for this can be **-32767** to **32767**.

Analog Output Setup

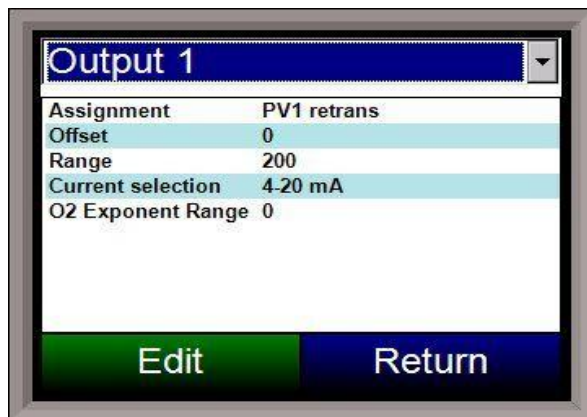

The 9120 controller has the option of two analog outputs. The outputs are ranged for a 4 – 20 milliamp signal or a 0 – 20 milliamp signal. Each output comes with a factory default configuration dependent on the application. Each output can be modified prior to shipment to your facility or in the field by a supervisor.

Analog Output Terminals:

Analog output 1 – terminals 24 and 25

Analog output 2 – terminals 25 and 26

Assignment

The analog output assignment can be modified depending on your system requirements. To change the Assignment, first select which analog output you want to change by selecting it in the pull-down menu. Select the desired assignment from the list and click **OK**. The following is a list of the options:

PV 1 retrans	Input 1 retrans
Loop 1 inc	Input 2 retrans
Loop 1 dec	Input 3 retrans
Loop 1 combo	Not Used
PV 2 retrans	O2 offset log
Loop 2 inc	SP1 retrans
Loop 2 dec	SP2 retrans
Loop 2 combo	SP3 retrans
PV3 retrans	Programmer ID number
Loop 3 inc	
Loop 3 dec	
Loop 3 combo	

Combo example for carbon – 4 – 12 mA Air
12 – 20 mA Gas

Offset

This is the starting point; the Process Variable value at which you get 4 milliamps. Clicking on this value will display an input box from which the user can select a new value. The range is – **32767** to **32767**.

Range

This is a Process Variable value between 4 and 20 milliamps. Clicking on this value will display an input box from which the user can select a new value. The range is –**32767** to **32767**. Note - The range, although not displayed with a decimal point, contains a decimal point that is dependent on the process variable selected. For example, If the offset is 20 mV for 4 mA, and you want 100 mV to be 20 mA, then your range should be 80. If the process variable is temperature, then the range will be 80, since temperature PVs do not have a decimal. If the PV is % Carbon, then the range will need to include the two decimal points for % Carbon. So, a range of 80 will be entered as 8000. See below for more examples.

Current Selection

Provides the option of **4-20 mA** or **0-20 mA** control.

Offset and Range when assigned to a control loop

Inc -- 0 = 4mA, 100 = 20mA

Dec -- 0 = 4mA, -100 = 20mA

Example: if 4 – 20 mA = 800 mV - 1200 mV and PV is Temperature

Offset = 800 (starting point)

Range = 400

Example: if 4 – 20 mA = 800 mV - 1200 mV and PV is O2
Offset = 800 (starting point)
Range = 4000 (400.0)

Example: if 4 – 20 mA = 800 mV - 1200 mV and PV is % Carbon
Offset = 800 (starting point)
Range = 40000 (400.00)

O2 Exponent Range

This menu option will allow the user to set the Oxygen exponent range. The range is **-32767** to **32768**.

Alarm Setup

The 9120 controller can be configured to use three different alarms. Each of the alarms consists of an alarm setpoint, alarm source, alarm type, hysteresis, smart alarm, alarm on delay time, and a zero SP blocks alarm value. The alarms come from the factory with a default configuration dependent on the application but also can be modified prior to shipment to your facility or in the field by a supervisor. Press the alarm dropdown menu to choose between them.

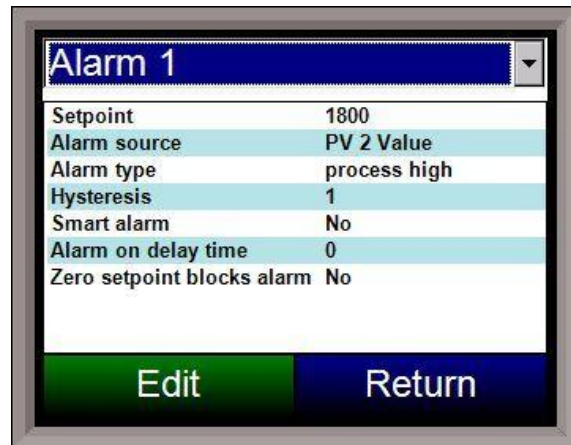

Setpoint

This value is the setpoint for the alarm. The range is from **-32767** to **32767**.

Alarm Source

This value is the source of alarms used.

The options are:

PV 1 Value

PV 2 Value

PV 3 Value

Input 1 Value

Input 2 Value

Input 3 Value

Percent output 1 Value

Percent output 2 Value

Percent output 3 Value

Alarm Type

This value is the type of alarms used.

The options are:

Process High

Process Low

Band, Normally Open

Band, Normally Closed

Deviation, Normally Open Deviation, Normally Closed

Deviation alarm is single sided. i.e. a +10 deviation will alarm when the PV is greater than SP + 10 but not neg. A -10 deviation will alarm when the PV is less than SP -10 but not on the positive side.

The actual relay setup with that alarm will only energize depending on the setpoint. For the standard alarms (1, 2, and 3), the user can select if the alarm condition is for above or below. This will dictate when the relay will energize.

Example: alarm 1 set to plus 10F will alarm 11 degrees above setpoint and pull in the relay. It will show alarm 10 degrees below but not pull in the relay.

A Band alarm will activate and energize the relay on both sides (+) and (-).

Note - some alarm types may be fixed at the current value.

Hysteresis

The hysteresis is in degrees, i.e. 10 hysteresis = 10 degrees. Alarm hysteresis should not have a decimal place. It is in units. If it is a control loop doing on/off control then the decimal place on the reset (hysteresis) should be ignored. The Hysteresis is a set number that works with the alarm to help control a motor or pump longer to reach a set amount to come back into band before it will shut off motor or pump.

Example: Using quench oil as an example, assume the SP is 200F. The alarm is set as a deviation of +10F. At 210 the alarm is active and the pump will run to cool the oil. With a hysteresis of 8 degrees the alarm and pump will turn off at 202F. It will turn back on when it is 10 degrees above setpoint. If the setpoint is still 200 then at 210 it is on again. Clicking on this value will display an input box from which the user can select a new value.

The range is from **-32767** to **32767**.

Smart Alarm

This value is a display of the Smart Alarm status. A smart alarm is an alarm that works with a Process Variable and when enabled it will not be active until the process variable is within band of the setpoint.

Example: If the SP is 1700 and the band is 10 degrees the alarm will not be active until the PV reaches 1690.

The value can be either **Yes** or **No**.

Alarm on delay time

This value is the on Delay Time for the Smart Alarm, in seconds. If the timer is utilized the alarm will not be active until in band and the timer has timed out (this is in seconds).

Example: If you select 30, the output will not energize until 30 seconds after the alarm is active.

Clicking on this value will display an input box from which the user can select a new value.

Note – This value is fixed at **No** for Alarm 1.

The range is from **-32767** to **32767** seconds.

Zero SP Blocks Alarm

This value will allow a 0 setpoint to block an alarm. Note – This value is fixed at **No** for Alarm 1. The options are either **No** or **Yes**. Note – Setting this value to **Yes** will force the Smart Alarm value to be set to **No**

Aux Analog Input Setup

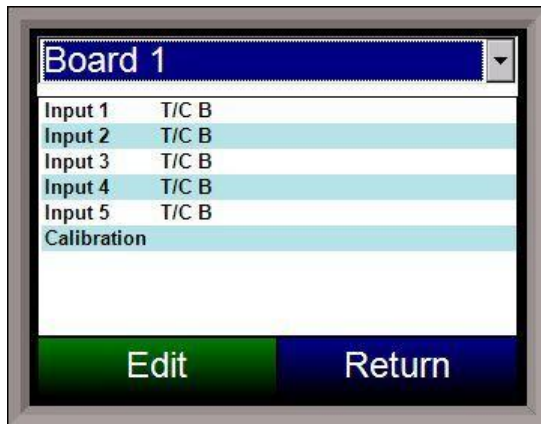

This option will allow the user to select the input type for the auxiliary analog input boards, as well as calibrate the boards.

Input 1 – Input 5

This will set the input type for the selected input.

The options are:

T/C B	2.5 Volts
T/C C	1.25 Volts
T/C E	160 mV
T/C J	80 mV
T/C K	40 mV
T/C N	20 mV
T/C NNM	4-20 mA/124 Ω
T/C R	4-20 mA/62 Ω
T/C S	
T/C T	

Calibration

This menu option will allow the user to calibrate the auxiliary analog inputs.

Overview

The auxiliary analog inputs can be calibrated using the touch screen and a calibrator. Before performing this procedure on a newly installed controller, the unit needs to be powered on for

at least thirty (30) minutes for a warm up period to allow the inputs/outputs to stabilize with the environment.

Each auxiliary analog input has a zero and span calibration value. A cold junction trim value must be calibrated for thermocouple inputs. **The cold junction trim value must be performed, if necessary, after the zero and span calibration.**

Equipment needed

A certified calibrator(s) with the ability to source and measure millivolts, milliamps and thermocouples is required. The appropriate connection leads are also required. A 24VDC 75-watt power supply is required. It is important to note that when performing a zero or span calibration, **do not use** regular thermocouple wiring. Instead, use any kind of regular sensor wire, or even regular copper wire. To perform the calibrations, the user will need a calibrator that is capable of sourcing volts, millivolts, and temperature.

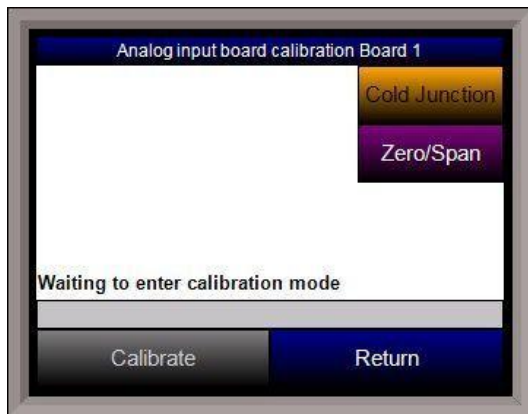

e input.

The user will need to select which calibration type – Zero/Span or Cold Junction – is to be performed and press the appropriate button from the main calibration screen. **The cold junction trim value must be performed, if necessary, after the zero and span calibration.**

Input - Zero Calibration

To perform a zero calibration on an input, verify that the “Zero” option at the left is selected. Select the target millivolts that will be sourced. Note – For a zero calibration, it is recommended that 0 mV be sourced. The recommended millivolt source value will be displayed as well. The mV value will be displayed on the screen under the appropriate input. Select the input(s) to be calibrated. Press the **Calibrate** button to begin the calibration. The calibration status will be displayed on screen. When it is over, the screen will display “Waiting to start zero/span calibration” once again. Once the zero calibration has finished, the span calibration can be performed.

Calibration Procedure

The calibration procedure for an auxiliary analog input will be the same regardless of which operation is being performed.

1. Zero Input: Source a zero mV value to the terminals. Press the **Calibrate** button.
2. Span Input: Source a specific mV value to the terminals and enter the value in the box. Press the **Calibrate** button.
3. Cold Junction Trim: Enter the temperature of th

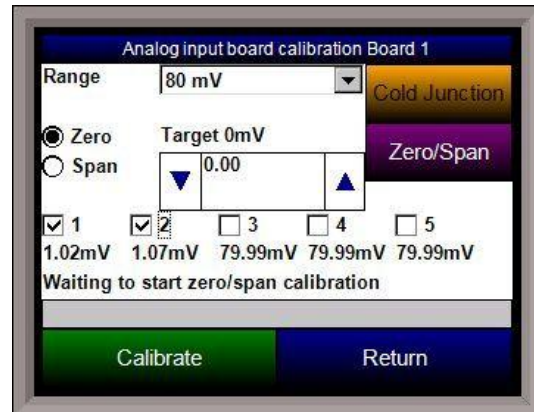

Input – Span Calibration

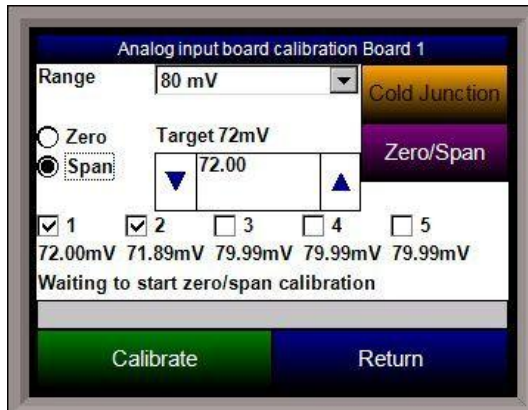

To perform a span calibration on an input, verify that the “Span” option at the left is selected. Select the target millivolts that will be sourced. Note – For a span calibration, it is recommended that 90 % of the full range be sourced. The recommended millivolt source value will be displayed as well. The mV value will be displayed on the screen under the appropriate input. Select the input(s) to be calibrated. Press the **Calibrate** button to begin the calibration. The calibration status will be displayed on screen. When it is over, the screen will display “Waiting to start zero/span calibration” once again. Once the zero and span calibration have finished, a cold junction trim

can be performed, if necessary.

Cold Junction

The cold junction should be performed after any zero/span calibration. To perform a cold junction, the corresponding T/C wire will need to be setup on the inputs. A specific temperature will need to be sourced to the selected input. The input’s PV value will be displayed on the screen. Determine the difference between the displayed PV value and the value that is being sourced.

For example, assume that input 3 is setup for T/C type K, and 1000 °F is being sourced in. The PV for input 3 is 1002 °F. The value displayed on the cold junction screen is the current temperature of the terminals. Assume this value is 95.5 °F. In the number box, the user would enter a -2 degree difference, or 93.5 °F, since the temperature sourced (1000 °F) – PV value (1002 °F) = -2 °F. Press the Calibrate button to finish off the cold junction calibration. Return to the main screen to see if the selected input’s PV value is now displaying the correct value of what is being sourced. If necessary, repeat these steps to further calibrate the cold junction value.

Calibration

Overview

The series 9120 controller can be calibrated using the touch screen and a calibrator. Before performing this procedure on a newly installed controller, the unit needs to be powered on for at least thirty (30) minutes for a warm up period to allow the inputs/outputs to stabilize with the environment.

The series 9120 has three analog inputs. Each range has a zero and span calibration value. A cold junction trim value must be calibrated for thermocouple inputs. **The cold junction trim value must be performed, if necessary, after the zero and span calibration.** There are two analog outputs each with a zero and span value.

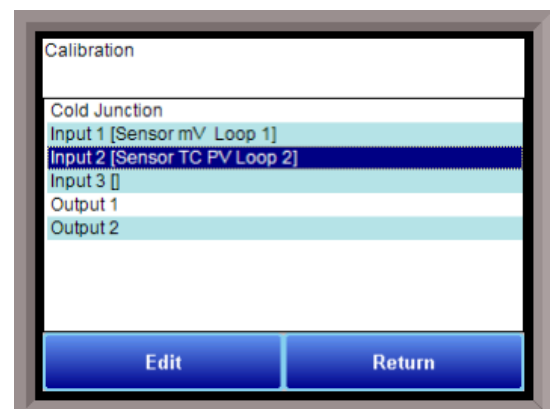

Equipment needed

A certified calibrator(s) with the ability to source and measure millivolts, milliamps and thermocouples is required. The appropriate connection leads are also required. A 24VDC 75-watt power supply is required. It is important to note that when performing a zero or span calibration, **do not use** regular thermocouple wiring. Instead, use any kind of regular sensor wire, or even regular copper wire. To perform the calibrations, the user will need a calibrator that is capable of sourcing volts, millivolts, and temperature.

Calibration Procedure

The calibration procedure for an input or output will be the same regardless of which operation is being performed.

1. Zero Input: Source a zero mV value to the terminals. Press the **Calibrate** button.
2. Span Input: Source a specific mV value to the terminals and enter the value in the box. Press the **Calibrate** button.
3. Zero Output: Press the **Ready** button, which will set the output to 0%, or 4 mA. Measure the current at the terminals and input the measured value. In the number box, use the arrows or tap the box to enter the value with the key pad. Press the **Calibrate** button.
4. Span Output: Press the **Ready** button, which will set the output to 100%, or 20 mA. Measure the current at the terminals and input the measured value. In the box, use the arrows or tap the box to enter the value with the key pad. Press the **Calibrate** button.
5. Cold Junction Trim: Enter the temperature of the input.

Input - Zero Calibration

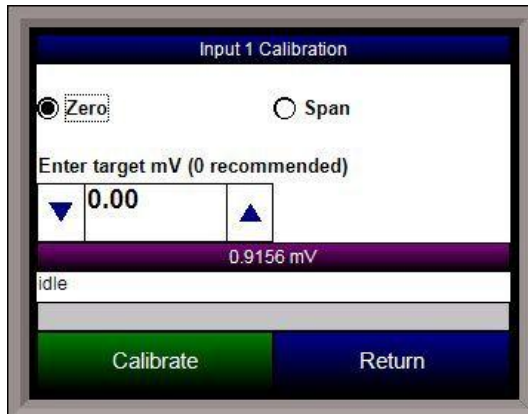

To perform a zero calibration on an input, verify that the “Zero” option at the top is selected. Select the target millivolts that will be sourced. Note – For a zero calibration, it is recommended that 0 mV be sourced. The recommended millivolt source value will be displayed as well. The mV value will be displayed on the screen. Press the **Calibrate** button to begin the calibration. The calibration status will be displayed on screen. When it is over, the screen will display “idle” once again. Once the zero calibration has finished, the span calibration can be performed.

Input - Span Calibration

To perform a span calibration on an input, verify that the “Span” option at the top is selected. Select the target millivolts that will be sourced. Note – For a span calibration, it is recommended that 90 % of the full range be sourced. The recommended millivolt source value will be displayed as well. The mV value will be displayed on the screen. Press the **Calibrate** button to begin the calibration. The calibration status will be

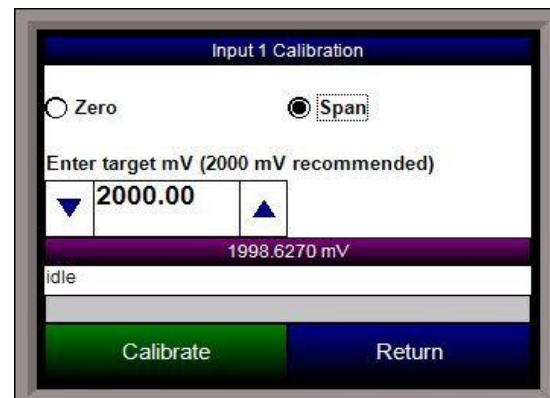

displayed on screen. When it is over, the screen will display “idle” once again.

Output – Zero Calibration

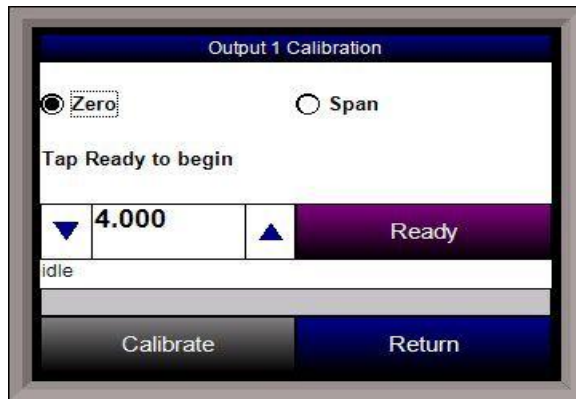

To perform a zero calibration on an output, verify that the “Zero” option at the top is selected. Press the **Ready** button to begin the process. Enter the mA value that is being measured at the appropriate terminals (see the 9120 Wiring Terminals section; the appropriate terminals to measure will also be displayed on the screen). Press the **Calibrate** button to finish the calibration. The calibration status will be displayed on screen. When it is over, the screen will display “idle” once again. Once the zero calibration has finished, the span calibration can

be performed.

Output – Span Calibration

To perform a zero calibration on an output, verify that the “Span” option at the top is selected. Press the **Ready** button to begin the process. Enter the mA value that is being measured at the appropriate terminals (see the 9120 Wiring Terminals section; the appropriate terminals to measure will also be displayed on the screen). Press the **Calibrate** button to finish the calibration. The calibration status will be displayed on screen. When it is over, the screen will display “idle” once again.

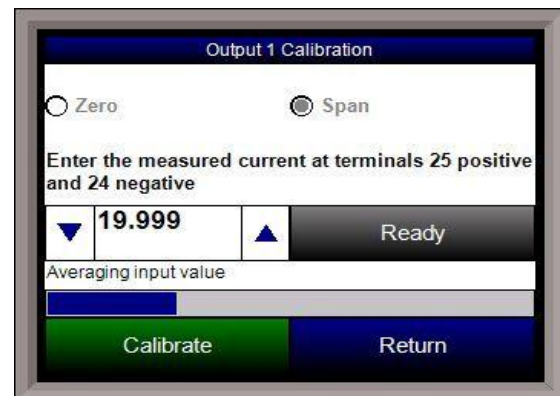

Cold Junction

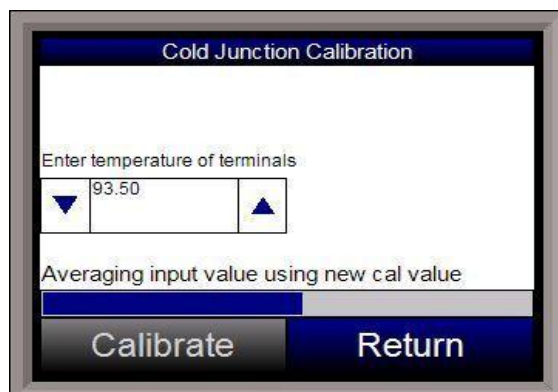

The cold junction should be performed after any zero/span calibration. To perform a cold junction, the corresponding T/C wire will need to be setup on the inputs. A specific temperature will need to be sourced to the selected input. Return to the main screen by pressing the **Return** button three times to read the input’s PV value. Mark down the displayed PV value and determine the difference between the displayed PV value and the value that is being sourced.

For example, assume that input 3 is setup for T/C type K, and 1000 °F is being sourced in. On the main display, the PV for input 3 is 1002 °F. Return to the Cold Junction menu under the Calibration menu. The value displayed on the Cold Junction Calibration screen is the current temperature of the terminals. Assume this value is 95.5 °F. In the number box, the user would enter a -2 degree difference, or 93.5 °F, since the temperature sourced (1000 °F) – PV value

(1002 °F) = -2 °F. Press the Calibrate button to finish off the cold junction calibration. Return to the main screen to see if the selected input's PV value is now displaying the correct value of what is being sourced. If necessary, repeat these steps to further calibrate the cold junction value.

Tuning Assistant

The tuning assistant menu option will allow the user to automatically generate the PID loop settings for the control loops in the 9120 controller.

The tuning assistant can be performed on either Loop 1 or Loop 2.

Note - The four buttons at the bottom of the screen: **Use UD**, **Use CD**, **Use OD**, and **Use PI** will be inaccessible until some PID settings are loaded into the PID settings list above the buttons.

The user can select the tuning option from the top left of the screen. The choices are: **Relay**

and **Limited Relay**. This option will allow the user to limit the output value while the controller is controlling the furnace. Normal operation will typically use 100 % output. When the limited relay option is selected, the "Tuning Delta:" label and an edit box will be displayed. When the **Relay** option is selected, the "Tuning Delta:" label and the edit box will be hidden. The "Tuning Delta" value will be the amount to limit the controller by. Pressing the edit box will display the numeric keypad, which will allow the user to enter the limiting value.

The "Conservative" option will allow the user to minimize, if not remove, the possibility for an overshoot of the setpoint. If a small overshoot is acceptable, leave the "Conservative" checkbox unchecked. If, however, no overshoot is desired, then checking the "Conservative" checkbox will accomplish this.

The process variable as well as the setpoint for the selected loop will be displayed below the "Conservative" option.



list will be populated with suggested values and the four buttons underneath will be enabled. The line below the PID settings list will read "Idle" again as well.

The user has the option to select only one of these sets of values: the Under Damped set (Use UD), the Critically Damped set (Use CD), the Over Damped set (Use OD), or the PI set (Use PI). To select the set of

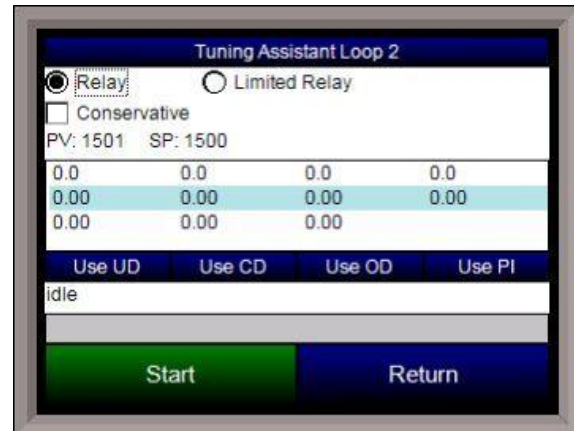

Pressing the **Start** button will begin the auto tune process. Note - The process may take a few seconds to start. The "Idle" line will change to display the calibration process for the auto tune.

Note: The **Start** button will become the **Abort** button while the calibration is running. Pressing the **Abort** button will abort the process. If the **Abort** button is pressed while a calibration is running, a message box will be displayed confirming the action.

Pressing the **Yes** button will stop the auto tune calibration and exit the screen. The **No** button will cancel the abort.

When the calibration is finished, the PID settings

values, press the corresponding button. For example, to select the Critically Damped set of values, press the **Use CD** button. The under damped values will reach the setpoint faster, but there will be more overshoot involved. The over damped values will work to minimize the overshoot, but it will be slower than the under damped values. The critically damped values are considered the “optimum” values because they are a balance between the under damped and over damped values with regards to time and overshoot. The PI values are just the proportional band and the reset value (the P and the I from PID). This could be applicable in an atmosphere loop, where the rate won’t have much effect. Once a set of values has been accepted, the user can press the **Return** button to exit the screen. The accepted values can be viewed on the PID Loop Setup menu option. Note - Once the screen is closed out, the PID settings values will be lost. To populate these values again, another auto tune routine will need to be run.

Configuration

This option will allow the user to set some general configuration settings. The list of configurable items is:

- **Edit Event Text**
- **Compact Database**
- **Communications Setup**
- **Read/Write Data**
- **Edit Trend Charts**
- **Edit Datalogger**
- **Reset Datalogger**
- **Display**

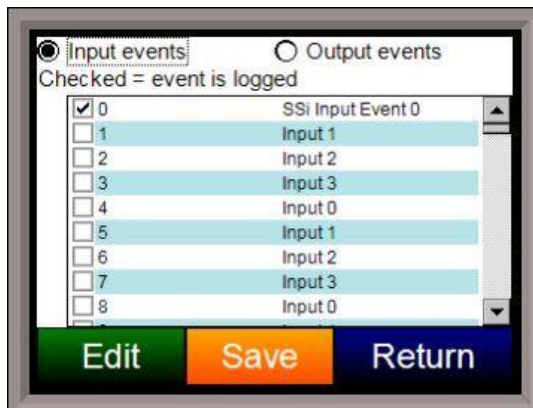

Edit Event Text

This menu option will allow the user to configure the text for the input and output events for the 9120. Select whether to edit the Input events or the Output Events. Note – The list of events can take a few seconds to load. The screen will refresh after the list has been loaded. There are a total of 148 input events, and 296 output events. Highlight the event to be changed and click on the **Edit** button. This action will display the on-screen keyboard, which will allow the user to modify the event text. To have that event

data logged, check the checkbox next to the event number. To save the changes to the event text, click on the **Save** button. Clicking on the **Return** button will not save any of the changes made. Note – Clicking on the **Save** button will not close the Edit Event Text screen.

Compact Database

This menu option will automatically compact the TS9120.sdf database. This database will keep track of all of the alarms, events, recipes, and system events that occur on the 9120. When records are added, space is reserved in the database table for the maximum amount of characters, regardless of the actual number of characters in the record. Once the record is

added, this space is not released. Instead, it will still be associated with the record, thereby adding to the total disk space and slowing down the communication time with the database. Compacting the database will free up this extra space, which will speed up the amount of time it takes the software to communicate with the database.

Communications Setup

This menu option will allow the user to determine how the Touchscreen will communicate with the 9120 instrument.

The Media option will be the type of connection the Touchscreen is using to connect to the 9120. The options are:

- COM1
- COM2
- COM3
- COM4
- Ethernet



If COM1 through COM4 is selected, the user will have to set the Address and the Baud rate as well. If Ethernet is selected, then user will have to enter the IP address of the 9120 instrument

The Address option is the slave address of the 9120 instrument for the COM port communications, or the Ethernet IP address for Ethernet communications. For the COM port communications, the address will range from 1 to 250. For Ethernet communications, the address must be supplied in a 999.999.999.999 format, or it will not be accepted.

The Baud option is the baud rate for the COM port communications. The options are:

- 1200
- 2400
- 4800
- 9600
- 14400
- 19200
- 28800
- 38400
- 57600
- 76800
- 115200

Read/Write Data

This menu option is protected by the SSI special passcode. Contact SSI at 800-666-4330 to obtain this passcode, and before making any changes.

This menu option is used mainly for technical support reasons. It will read the registers from the 9120 and display those registers on the screen. The user will be able to read from and write to the 9120's registers. When the screen is first displayed, it will read the first 100 registers from the 9120 and display them in a column

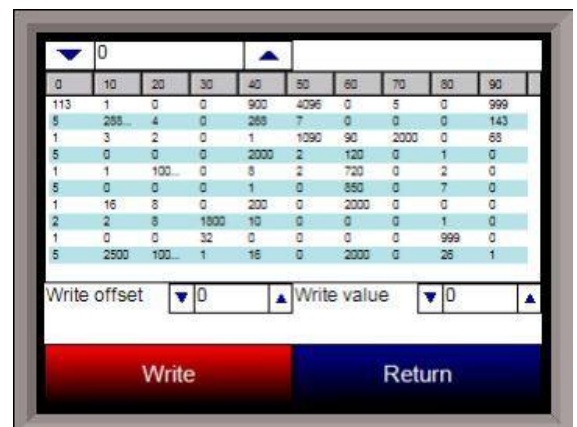

format. The top of the list will show “0”, “10”, “20”, etc. These are the column headers. Each value in the column will be a logical increment of the header, where the first value in the column equals the header value. For instance, column “0” will start with register 0, which in the picture has a value of “113”. The next value down is register 1, which has a value of “5”. The next value down is register 2, which has a value of “1”, etc. So, column “40”, 4 values down is register is register 43, which has a value of “2000”. The number box in the top left of the screen is the beginning register to read from. This will default to 0 when the screen starts. To read registers 100 – 199, edit the value to read “100”. Note – changing the value will automatically begin the read process. This process could take a few seconds to complete. The “Write offset” value will allow the user to write a specific value listed in the “Write value” box to the register listed in the “Write offset” box. Click on the **Write** button to write the value to the register. Click on the **Return** button to return to the Configuration menu.

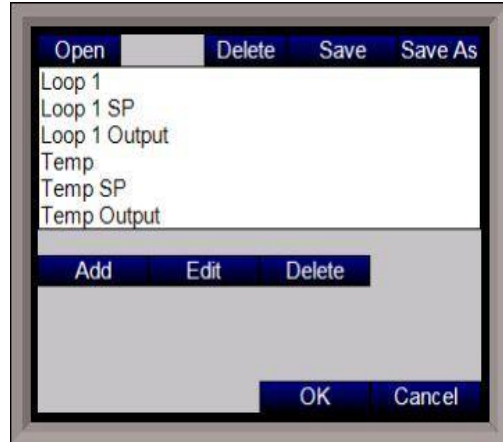

Edit Trend Charts

This menu option will allow the user to add, modify, or delete a trend chart from the Touchscreen. A trend chart is what displays the data logged data on the Touchscreen chart. Each trend chart file is made up of at least one trend, which represents one data value to display, such as temperature setpoint, or actual temperature value. The menu starts off with a blank new trend chart file. The buttons at the top will affect the trend chart file itself. **Open** will allow the user to open a selected trend chart. **Delete** will allow the user to delete a selected trend chart. **Save** will save the opened trend chart’s changes. **Save As** will allow the user to

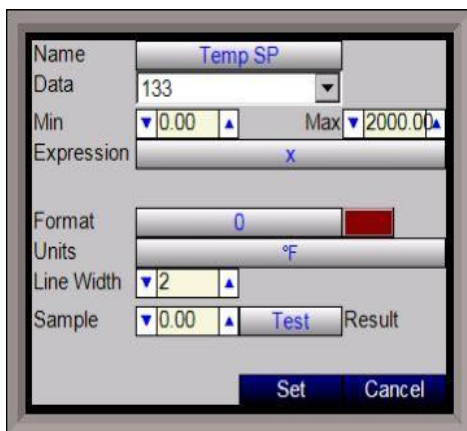

save the opened trend chart under a new file name. Once a chart has been opened, the buttons under the list of trends can be used. **Add** will add a new trend to the chart file. **Edit** will allow the user to edit a selected trend. **Delete** will allow the user to delete a selected trend. Each trend will have the same number of fields to be filled out when adding or editing. The “Name” is merely the name of the trend. This is how the trend will be identified on the chart screen. It will also be the physical name of the trend chart file. The list of values in the “Data” list are the specific registers that are being data logged. This list can be modified in the Edit Datalogger section that follows this section. Select the register that corresponds to the desired point to view. The “Min” field is the minimum

display value for the chart. The “Max” field is the maximum display value for the chart. The “Expression” field will format how the data value will be displayed on the screen. To display the data value as it is, enter an “x” as the expression. Note – Data values are stored in the 9120 without any decimal places, so formatting will be necessary for some values. If the data value was monitoring % Carbon, then the expression would be “x * 0.01”, since % Carbon values will need decimal places shown on the display. The “Format” field will control how the data value is displayed. This field works with the “Expression” field for display purposes. To display the data

value as it is, enter a "0". Note – Data values are stored in the 9120 without any decimal places, so formatting will be necessary for some values. If the data value was monitoring % Carbon, then the format would be "0.00", since % Carbon values will need decimal places shown on the display.

The following example will illustrate the difference between "Expression" and "Format". Assume that the data value represents a % Carbon value, and it's value is 3.47. This will be saved in the 9120 register as 347. Assume that "Expression" is set up as "x * 0.01" and "Format" is set up as "0.0". Whenever the data value is logged, it will be logged as 3.47, but it will display 3.8, since the "Format" only allows for 1 decimal place. If "Format" was "0.00", then the data value will display 3.47. However, if "Expression" was "x * 0.1" and "Format" was "0.0", the data value would be logged as 34.7 and display 34.7. If the "Format" was "0.00", the data value would be displayed as 34.70.

The color next to the "Format" field will allow the user to select which color the trend line will show up as on the chart.

The "Units" field will be the description of what kind of data value is being logged. This can be any value, such as "°F", or "%C", or "mV".

The "Line Width" field will allow the user to set the thickness of the trend line on the chart.

Lower numbers equal thinner lines, and higher numbers equal thicker lines. This may come in handy if both actual temperature and temperature setpoint have the same color. Actual temperature can have a line width of "1", and temperature setpoint can have a line width of "2". This will allow similar trends to be grouped by color.

The "Sample" field will allow the user to test out if the formatting of the trend line is correct. Enter a value in the number box and click on the **Test** button. The "Result" label will display the result based on the formatting selected.

Click on the **Set** button to save the trend line's values. Click on the **Cancel** button to not save any of the changes made.

Edit Datalogger

Note – Contact Super Systems before making any changes on this screen, since any changes made can have an adverse effect on the data being displayed.

This menu option will allow the user to modify which registers in the 9120 will be used as datalog data.

This list of data values is shown at the top of the screen.

Click on the **Add** button to add a new set of data values, or click on the **Edit** button to edit an existing set of data values. Click on the **Delete** button to delete a set of values. To add or edit data values, enter the initial offset of the register, as well as the number of sequential registers to read for. Using the example from the image, the data values added would be: 850, 851, 852, 853, 854, and 855. Clicking on the **Save** button will save the new data value registers. Note – The **Save** button must be clicked on to save any changes to the datalog data, including resetting the configuration. Clicking on the **Cancel** button will cancel the action. Clicking on the **Reset** button will reset the values to the original configuration. Note – any changes made to the data values will need a restart of the application before those changes will take effect. Clicking on the **Descriptions** button will display any descriptions for the data values. The default description for a data value is the data value's register. So the default description for data value 123 is

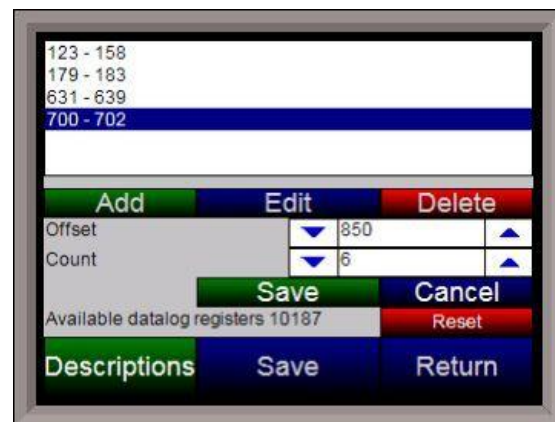

“123”. Changing this to “Calculated DP”, for example, would make it more descriptive. Register 123 holds the calculated dew point for PVT types: %Carbon, Dewpoint, O2, and Millivolts.



To add a new description, click on the **Add** button. To insert a new description, click on the **Insert** button. To delete a description, click on the **Delete** button. To edit an existing description, click on the **Edit** button. The Add or Insert feature will only create valid descriptions if there are existing data values without descriptions. Click on the **OK** button to save the description changes. Click on the **Return** button to cancel any changes and return to the previous screen.

Reset Datalogger

This menu option will reset all datalog data values and text descriptions back to their default values. Note – This menu option performs the same function as the **Reset** button on the Edit Datalogger menu screen. The main difference between the **Reset Datalogger** button and the **Reset** button on the Edit Datalogger menu screen is that the **Reset Datalogger** button will change the register descriptions back to their default text, while the **Reset** button will replace the text with the register number. This button is useful if the PVT type is changed and a reset is in order.

Display

This option will allow the user to decide what information will be displayed on the

Return

This option will return the user to the main menu screen.

Chart Screen

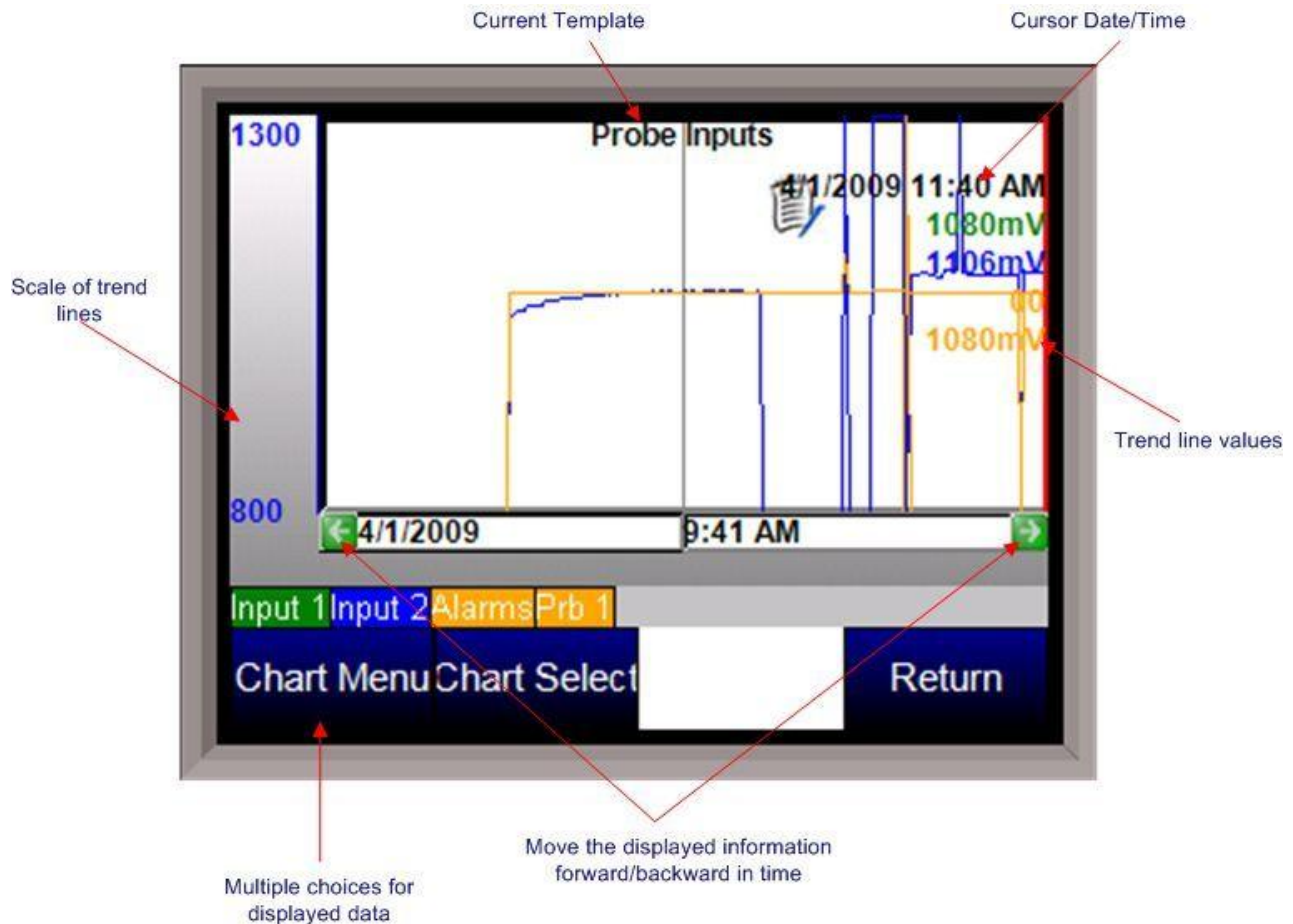

The Chart Screen will display the trend lines for the selected trend chart. The chart can be viewed either in real-time mode, or in historical mode. The left side of the screen will display the selected trend line's scaling, as set up in the Edit Trend Chart section of the Configuration menu. A trend line's scaling, name, and data will all be in the same color for ease of viewing. Pressing the scale bar (left side of screen - "Scale of trend lines" on image) will allow the user to cycle through the available trend scales. Even though multiple trend lines will have different scales, the lines will all be displayed on the same screen. The trend chart's name will be displayed at the top of the screen. The red vertical line is the chart's cursor. In realtime mode, the cursor is at the far right of the screen. The cursor can be moved by pressing on it and moving it left or right. Moving the cursor will display the trend values for the selected time. The chart can also be panned by pressing the green arrows to move forward or backward by the selected sample rate - 2 hours, 4 hours, etc. Pressing the trend names that are on top of the menu buttons will enable or disable the trend lines on the chart. This is useful if the user wishes to only view one or two trend lines on the chart. Disabled trend names will be in gray.

CO Factor

The CO factor allows the user to adjust the controller in order to match the results obtained when measuring shim stock. If the controller setpoint and the process variable are the same but the desired surface Carbon is not obtained, an adjustment can be made to the CO Factor to increase the amount of surface Carbon available to the parts. Lowering the CO factor immediately lowers the % Carbon process variable. This will cause the controller to add more enriching gas--- raising the process variable until once again the process variable and the setpoint match. Conversely, raising the CO Factor will cause the process variable to read higher, shutting down the enriching gas solenoid (possibly turning on the air dilution solenoid) causing the % Carbon process variable to begin to lower (NOT ADDING ENRICHING GAS) until the setpoint and process variable match.